



Environmental Noise Studies for Virgo during the O4 run

Irene Fiori - EGO

for the Virgo Collaboration



The 14th KAGRA International Workshop - Perugia - 15,16 May 2026

Outline

Natural noises:

- Wind

Characterization of detector susceptibility to:

- Magnetic noise
- Acoustic noise

Anthropogenic noises:

- Trains



Wind noise

In presence of intense winds Virgo experienced difficult in acquiring lock and a general worsening of the sensitivity, thorough O4

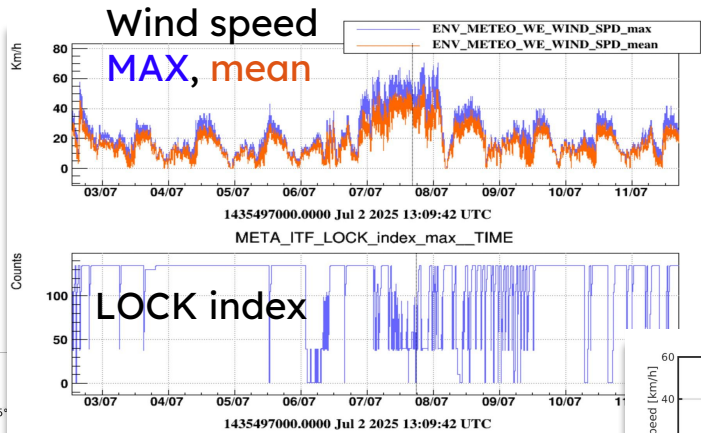

*Paper writing in progress -
A.Villano et al. [LIGO-G2600164](#)*

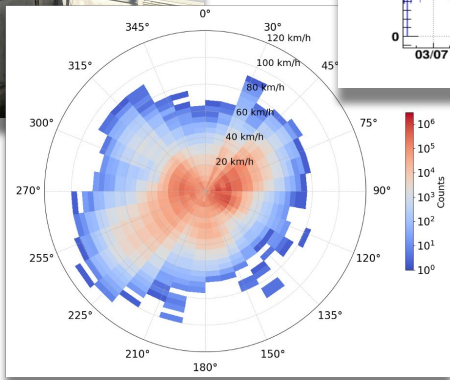

Selected **high** and **low** winds

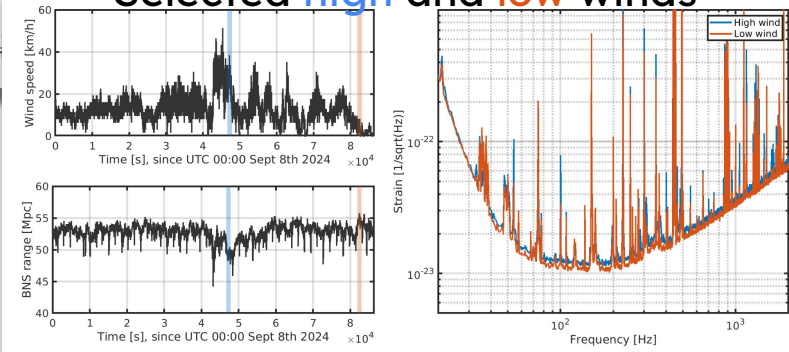

Wind noise - a statistical study of O4b dataset



Q. from Virgo Control Room: “Up to which maximum wind speed is it worth keep trying to lock?”

A. “As wind speed increases, the probability of successfully completing the locking sequence decreases dramatically. At a wind speed of about 40 km/h, the probability of not reaching the science mode is about one order of magnitude higher than that of reaching it.”

Q. “How many *Mpc* are lost as function of wind speed?” **A.** See the plot below:

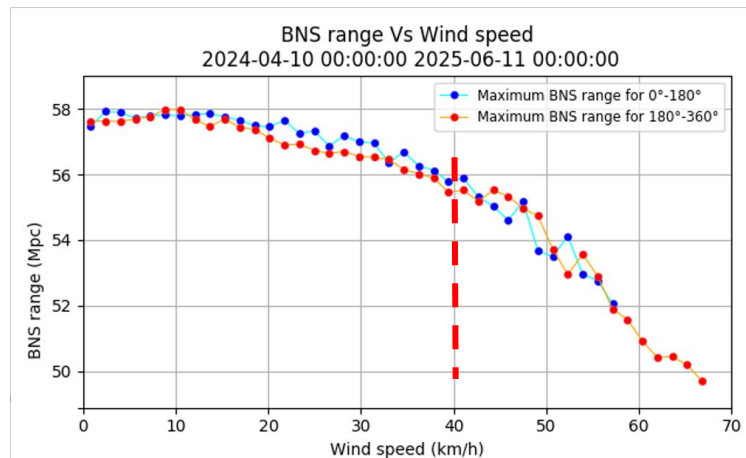
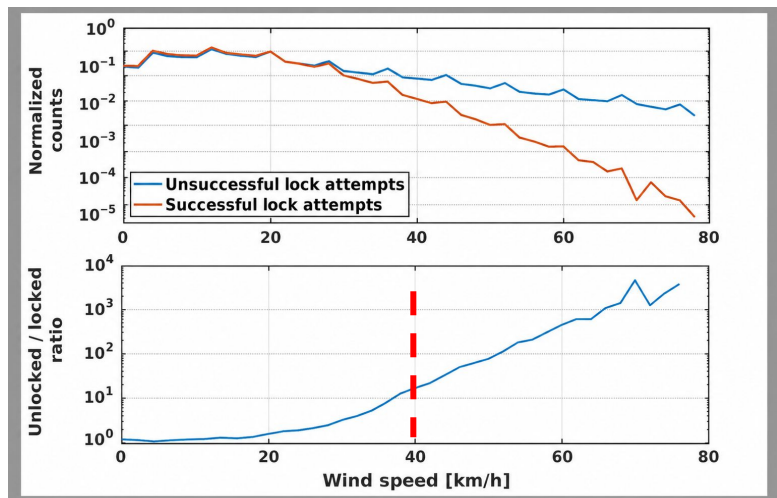

Dataset used: April 10th, 2024 to June 10th, 2025

(*) Each curve is normalized to the total number of locking attempts

Wind noise: path and outlooks



Wind causes tilt of the SAs tower base: a few tens of nrad at 10–100 mHz, which “fools” the SA accelerometers. Yet, we do not know how this tilt originates: is it the building floor (picture)? or is it induced by air pressure noise on the SA vacuum chambers? A study is ongoing.

In high winds:

- Locking difficulties: all SA controls are more noisy, impacting mainly on the OMC locking step
- Hrec noisier: increased coupling of frequency noise which is controlled by BS Ty

High wind
Low wind

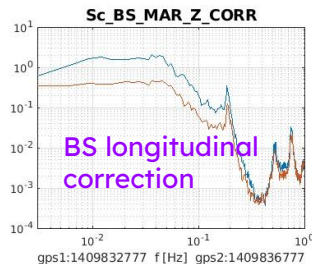
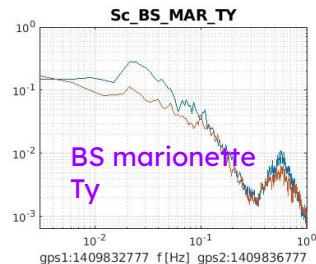
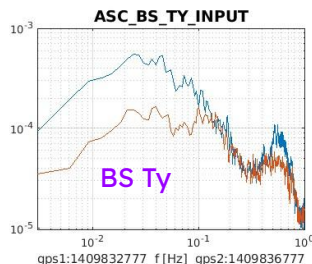
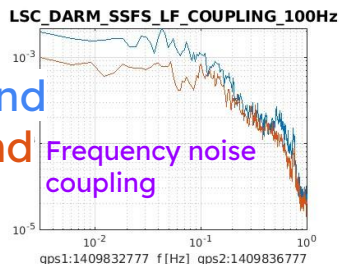

Credits: Paolo Ruggi

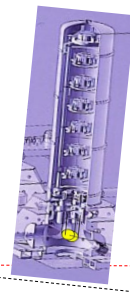
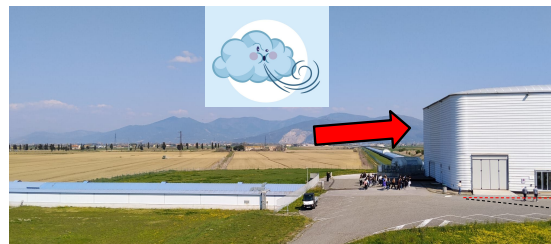

Impact on O4 duty cycle: **3.6%** (Wind and Earthquakes)

Which mitigation action?

- **BS control can be improved**
- **Wind screens is not easy for Virgo Buildings**

Magnetic susceptibility - measuring setup

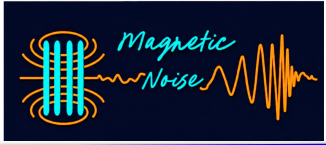

- Bartington triaxial magnetometer (ENV_TOWER_MAG_*)



Small coil

Central Building

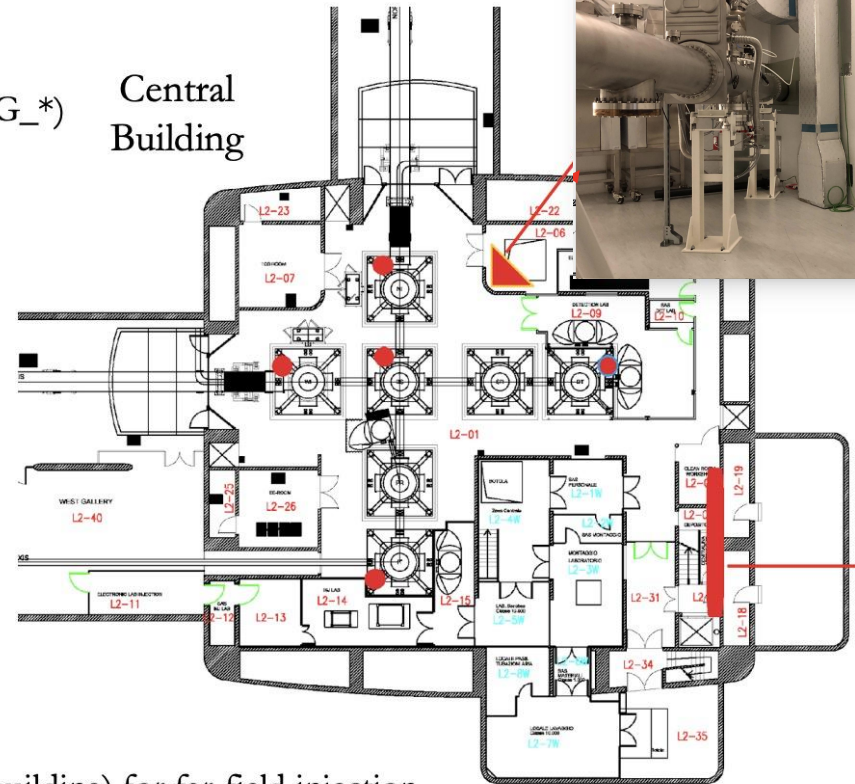

Metronix magnetometer (ENV_CEB_MAG_*)

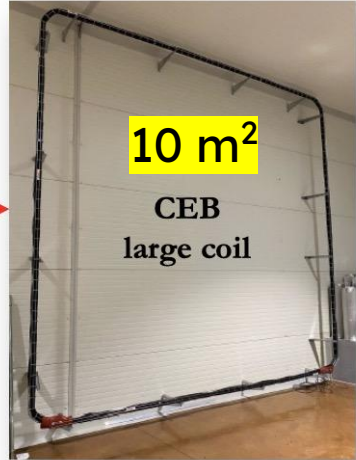

10 m²

CEB large coil

With power amplifier
KEPCO BOP
72-6DL-3MI

$$A_{\max} = 6 \text{ Apk}$$
$$V_{\max} = 72 \text{ Vpk}$$

- 3 large coils (one per building) for far-field injection.
- Triaxial magnetometer installed on **BS, NI, WI, INJ, DET, NE, WE** towers.
- Small coil for near-field injection (coil axis oriented along N, W, V).

Magnetic susceptibility - near field injections

Compare coupling at sensitive locations (TM towers, INJ and DET suspended benches) - [VIR-0300A-24](#)

Used small coil, injecting swept-sine current (10- 2000 Hz)

Results:

- TestMasses coupling:
 - ◆ Goes as $1/f^2$ (>> magnetic force on mirror)
 - ◆ Larger at WI... one missing mirror magnet(!)
- INJ and DET benches coupling:
 - ◆ Most susceptible elements are Faraday isolators (carry 1.5 T magnet)

Magnetic coupling, near field

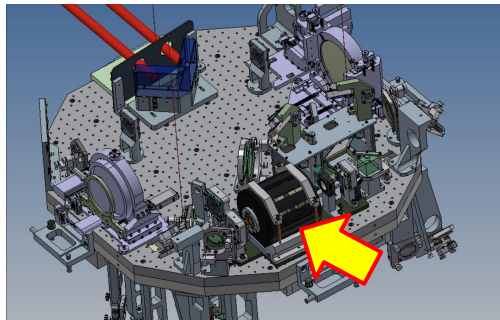
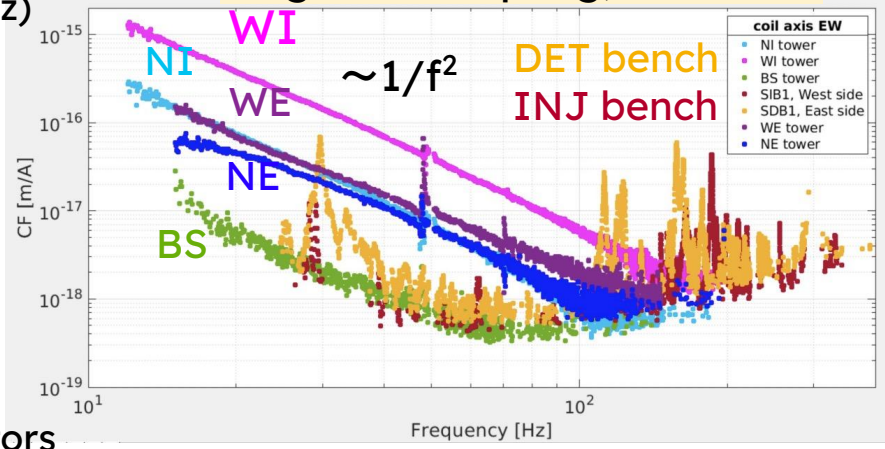

Faraday isolator on INJ bench

Mitigation actions:

Magnetic shields for the Faraday isolators (in progress) - [VIR-0061A-24](#) G.Quéméner

Magnetic susceptibility - far field injections

Used the Large wall coils (injections Automatized - with dedicated METATRON node):

- Swept sine currents (8 Hz - 2 kHz), ½ hour long, every 2 weeks during O4b and O4c
- Set of high current lines at low frequency (2-25 Hz) 900s each

Results:

- Coupling stable through O4. Most critical at WEB - extra noise associated to UPS module of vacuum pump (now off)
- Measured CFs have been used to estimate magnetic contribution to the Einstein Telescope - [ET-0058A-26](#)

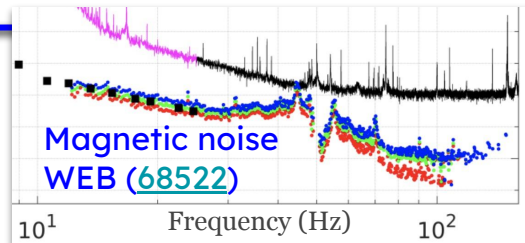

Projected contribution to Virgo O4 (here CEB only)

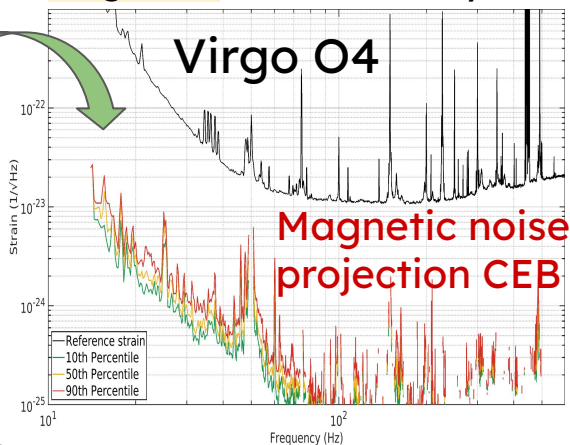
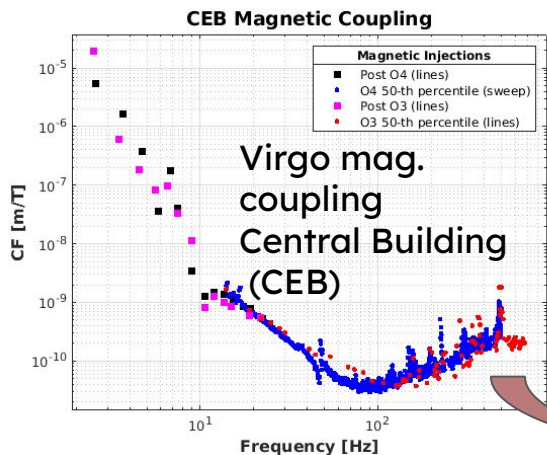

Estimate for the ET detector

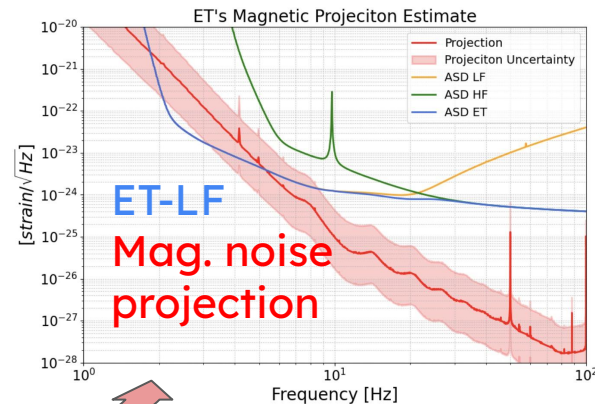

Acoustic susceptibility - the measuring setup

- Loudspeakers position

Broadband noise (40 Hz - 2 kHz)
injected every two weeks during O4

Central building

- 1 loudspeaker in Det terrace (#60928)
- Since Sep 2025:
 - 1 loudspeaker in Det lab (#67662)
 - 1 loudspeaker in Laser lab (#67772)

End Buildings

- 1 loudspeaker NEB
- 1 loudspeaker WEB

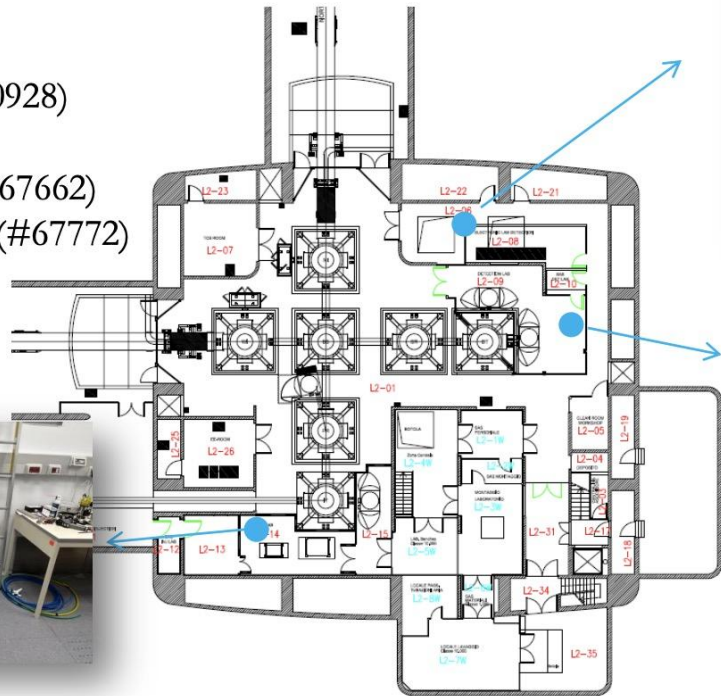

CEB Terrace



Detection laboratory



Laser laboratory



Acoustic susceptibility - West End building

Hints of a scattered light noise source located at the West End terminal station ([VIR-0944A-24](#)):

- Up-conversion noise during elevated micro-seism (sea activity) correlated with ground motion of WEB
- Acoustic injections at the WEB excited in hrec a noise bur around 100 Hz
- Tapping tests identified excess coupling from vacuum vessel several meters in front of WE

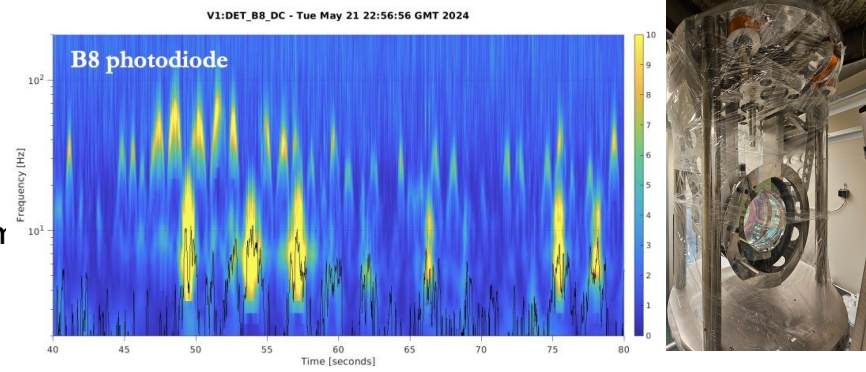

Origin identified:
 Missing AR coating of the outer baffle around the WE mirror payload

The baffle replacement reduced significantly the acoustic noise coupling to the detector

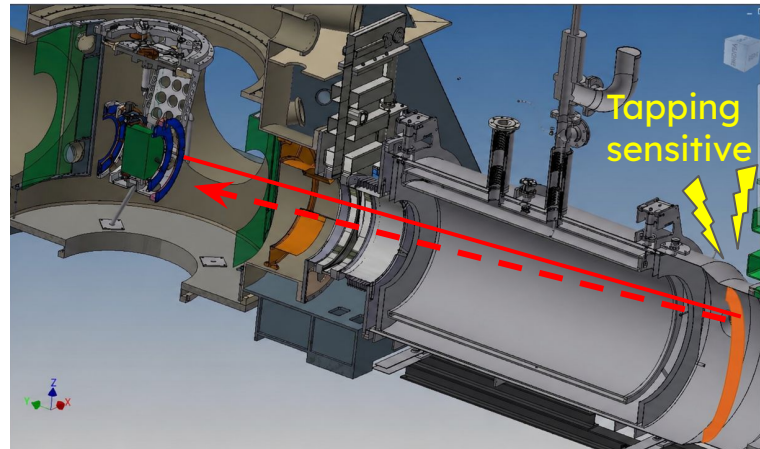
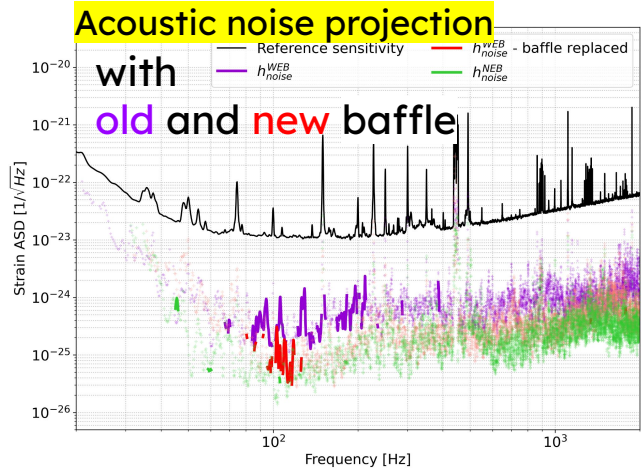

Credits: Tatiana Zelenova

Acoustic susceptibility - optical fibers

Acoustic noise from Laser lab HVAC (mainly 10-100Hz) was affecting the green laser sys (ALS)

Noise pick-up occurred along 16 m fibered green beams located inside the Laser lab. clean room

O4 patch-solution: reduced control bandwidth below 5 Hz. Not robust in case of bad weather (wind, sea).

O5 solution: “free space beating”. Remove the 16m fibered path, having the SHG source and the beating with green beams from the arms occurring in free space in one location (on External Injection Bench).

Successfully implemented: [elog 69001](#), [69085](#), *C. De Rossi* - [VIR-0343A-26](#).

Good result: green laser sys NOW immune from HVAC noise!

ALS sensitivity to acoustic noise: before (left) ... and now (right):

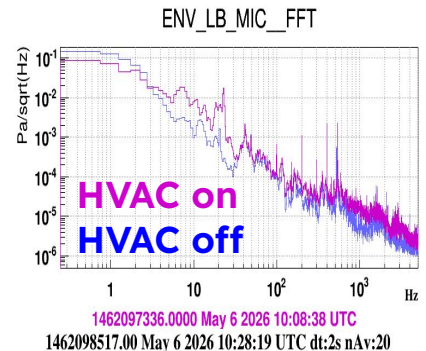
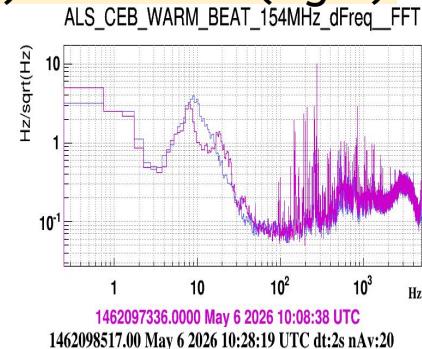
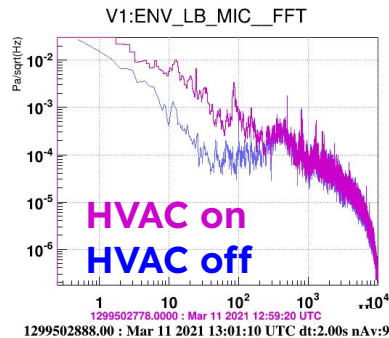
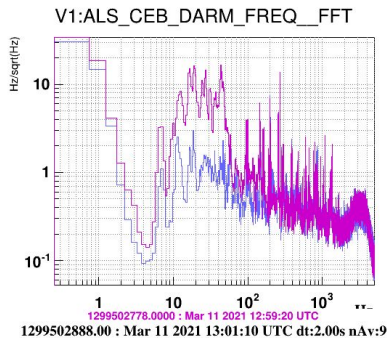

External environment - Train noise



Magnetic transients from trains are seen @Virgo site-wide!

Also measured amplification close to arm tubes (with T. Washimi).

Noise model:

- Produced by variable currents (\sim kA) in railway power lines.
- Fields propagates to Virgo through leakage currents in soil or directly radiated from power lines (2km away)

This noise is a potential issue for Einstein Telescope and the choice of the ET detector site.

Magnetometer inside North End Building

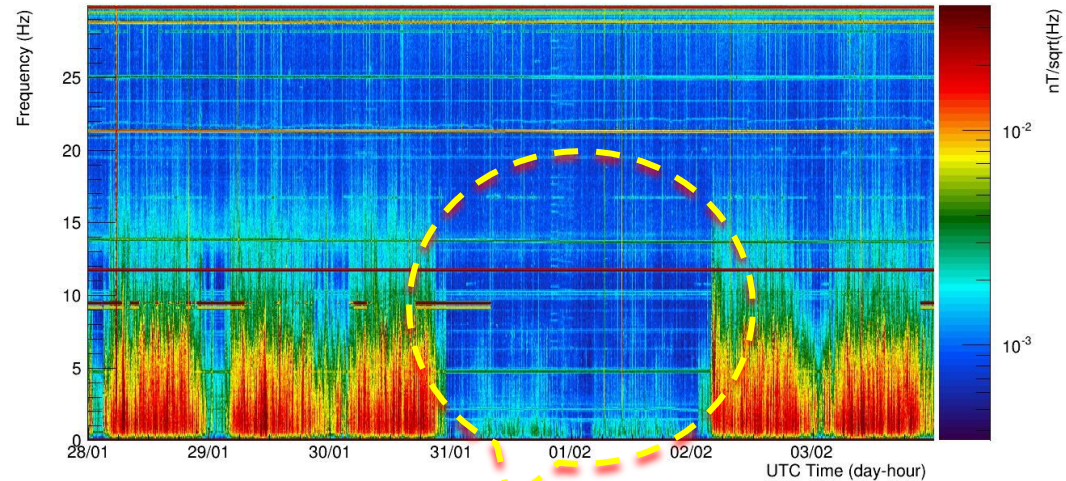

Jan. 31st and Feb. 1st 2026 the railway section Pisa-Empoli was de-energized for maintenance works (the railway is 2 km from Virgo North End Building)

External environment - improve monitoring

Three “external environmental stations”
One at ~50m from each vertex building. Shelter’s structure has (almost) no metallic parts.

Each equipped with:

- magnetometers, seismometer, microphone
- DC powered electronics

Aim for one station fully operational by IR1.

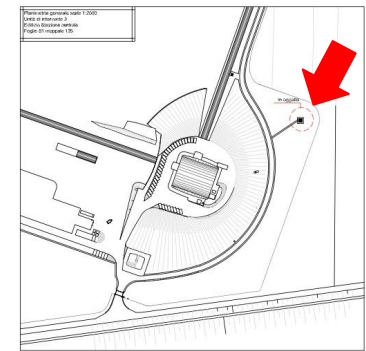
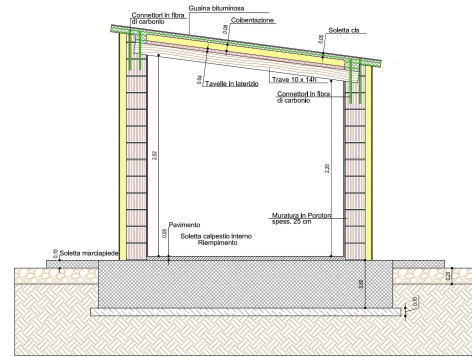

Concluding remarks

- Environment related noises encountered during O4 have been studied and either addressed (WE baffle) or understood (Wind)
- Some issues (sound and magnetic couplings) required further developments in view of future runs: green free-space beating, Faraday isolator shielding
- Magnetic noise studies are providing useful lessons for the Einstein Telescope

Thank you for your attention!