

The status of KAGRA

Takafumi Ushiba on behalf of the KAGRA collaboration
ICRR, KAGRA collaboration



Laser interferometric GW detector with cooled mirrors, constructed at the underground site.

Configuration of KAGRA

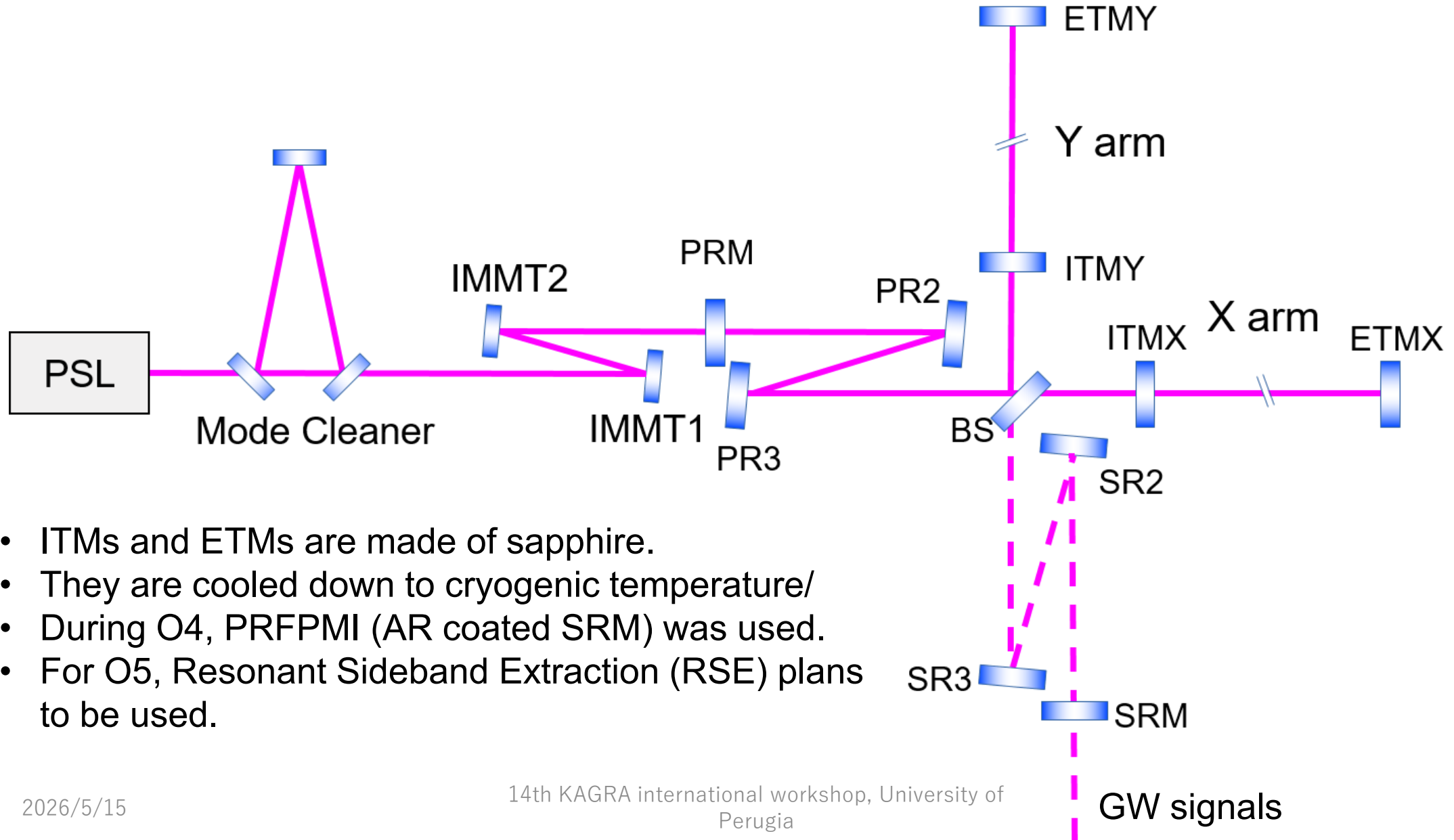

- ITMs and ETMs are made of sapphire.
- They are cooled down to cryogenic temperature/
- During O4, PRFPMI (AR coated SRM) was used.
- For O5, Resonant Sideband Extraction (RSE) plans to be used.

Brief history of KAGRA project

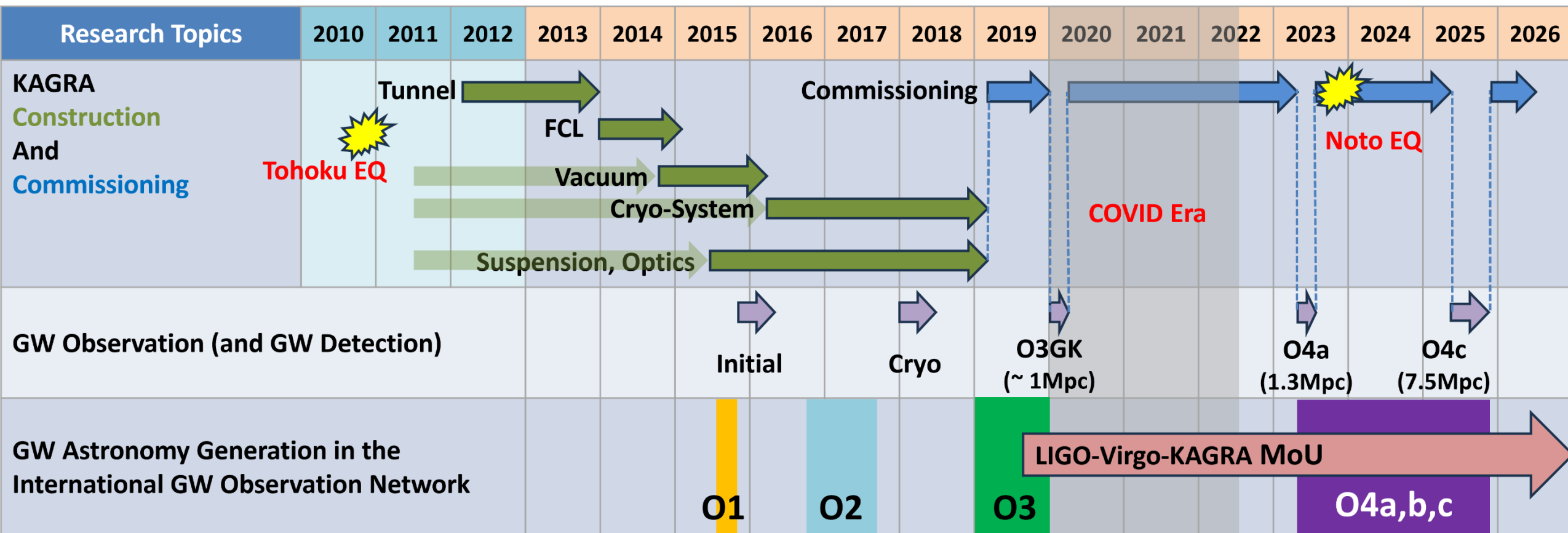

- KAGRA Project was officially funded by MEXT from 2010.
- KAGRA participated in the international collaboration with LIGO and Virgo, and LIGO-Virgo-KAGRA collaboration was formed in 2019.
- The observing run 4 (O4) was completed in November last year, and preparations for O5 are now underway.

Noto-Earthquakes damaged KAGRA on Jan 1, 2024

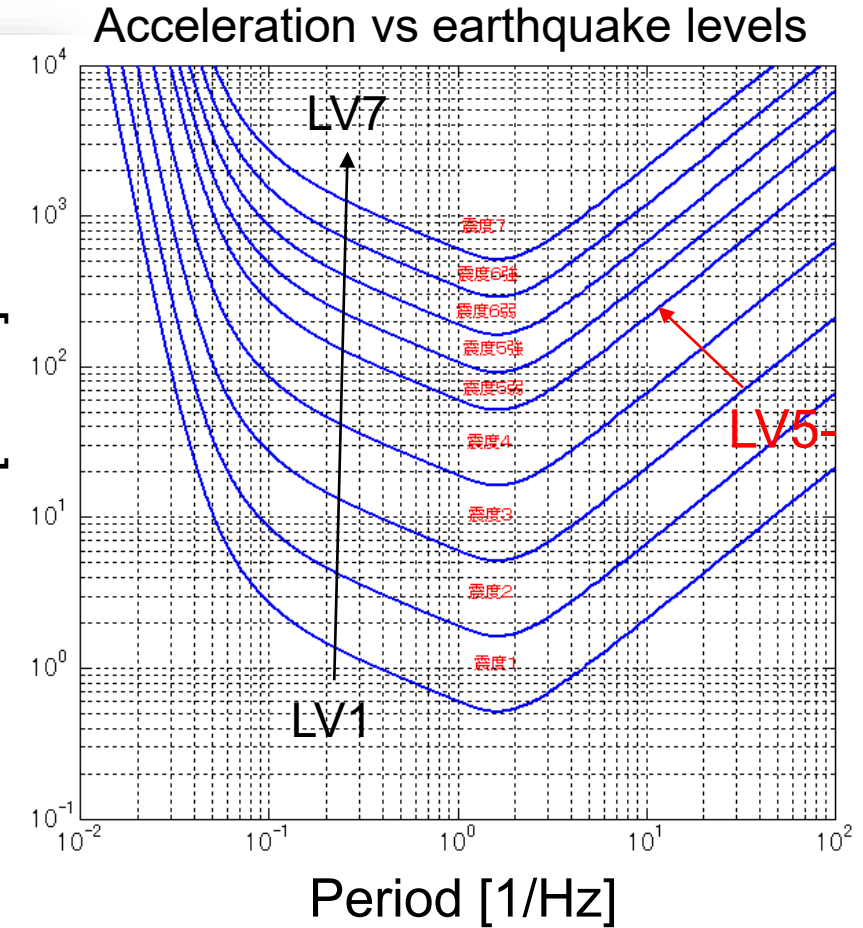

<https://www.jma.go.jp/jma/kishou/knownow/jjishin/kyoshin/kai setsu/comp.html>

● List of Large Earthquakes in the past 100 years

- 1909 Aug 14, M6.8 【Anegawa】 Lv.3
- 1944 Dec 7, M7.9 【Tounankai】 Lv.4
- 2011 Feb 17, M5.5 【Hida area】 Lv.3~4
- 2023 May 5, M6.5 【Noto Peninsula】 LV.2~3
- **2024 Jan 1, M7.6 【Reiwa 6 Noto Peninsula】 LV 5-**
- Lv.5- was the largest earthquake at least in the last 100 years.

2026/5/15 It took about a year to fully recover normal cryogenic interferometer operation.

Making strategy toward O4c

Noise budget during O4a

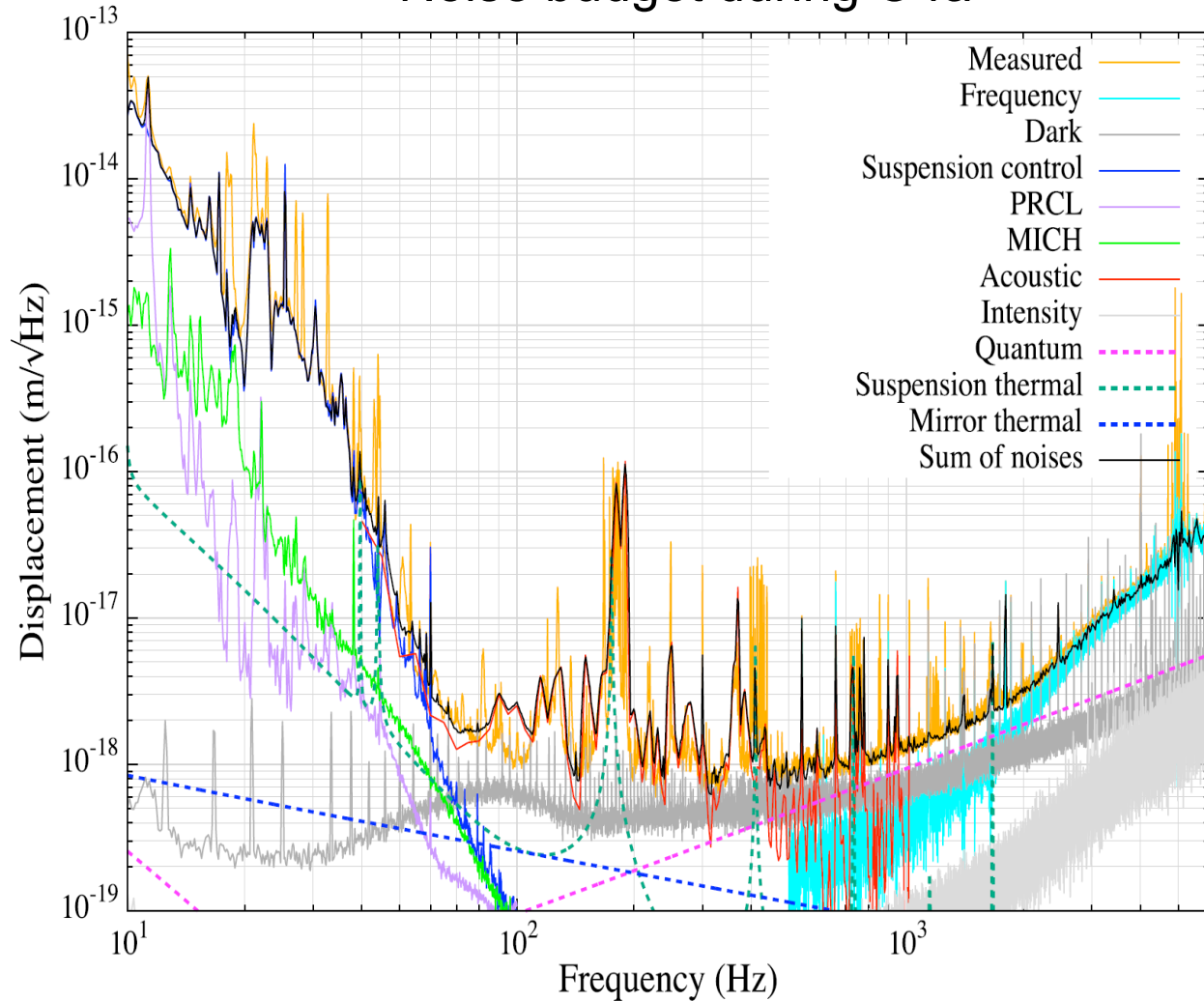

Target sensitivity for O4c

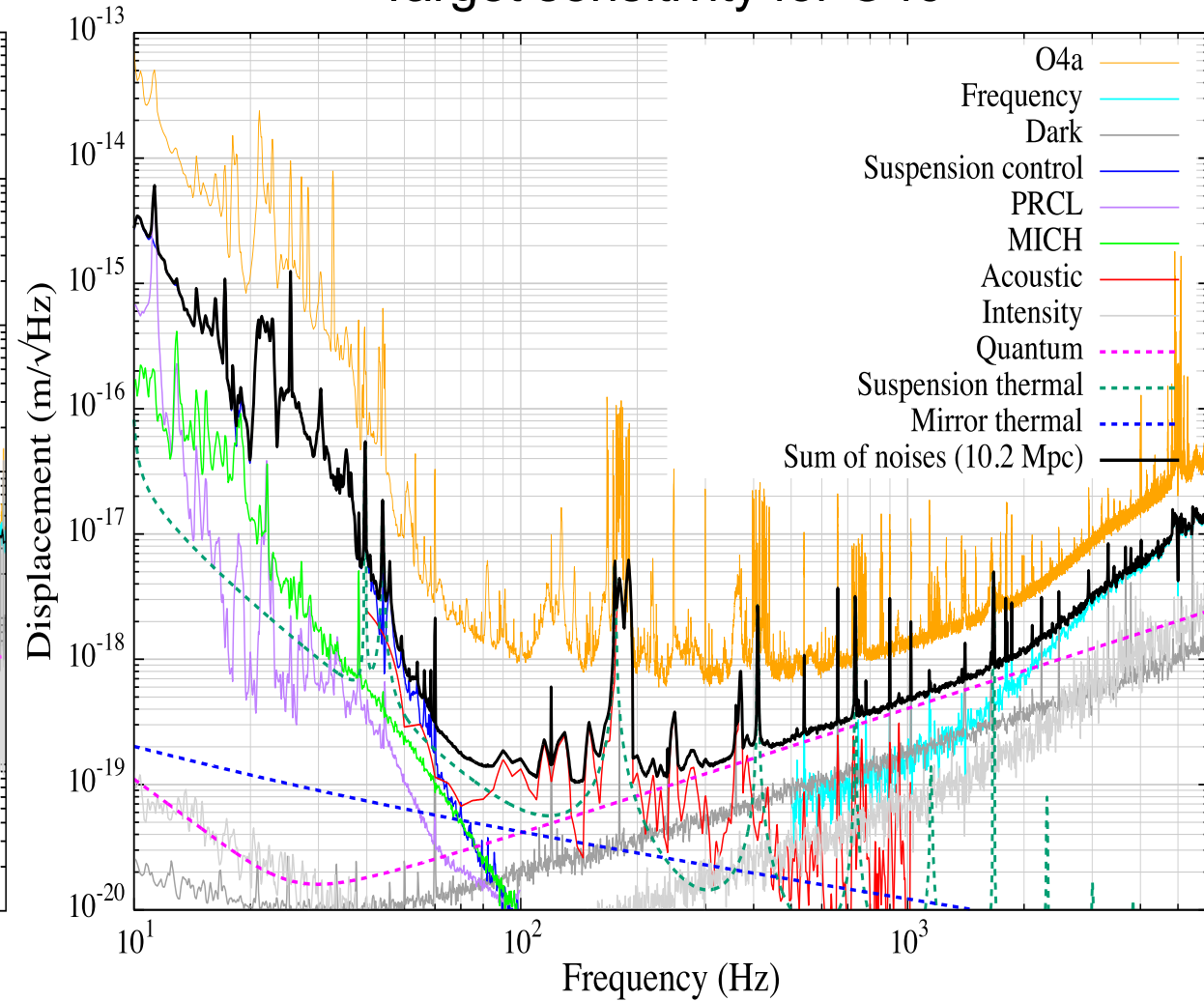

Making strategy toward O4c

- Local control noise reduction (1/10)
 - Update of local control scheme
- MICH/PRCL coupling noise reduction (1/10)
 - laser power increase
 - control optimization
- PD dark noise reduction (1/30)
 - Reduction of electrical coupling
 - Laser power increase
- Thermal noise reduction (1/6)
 - Cooling mirrors
- Quantum noise (shot noise) reduction (1/3)
 - Laser power increase
- Acoustic noise reduction (1/30)
 - Coupling function reduction
 - Noise source mitigation
- Frequency noise reduction (1/2)
 - Coupling function reduction

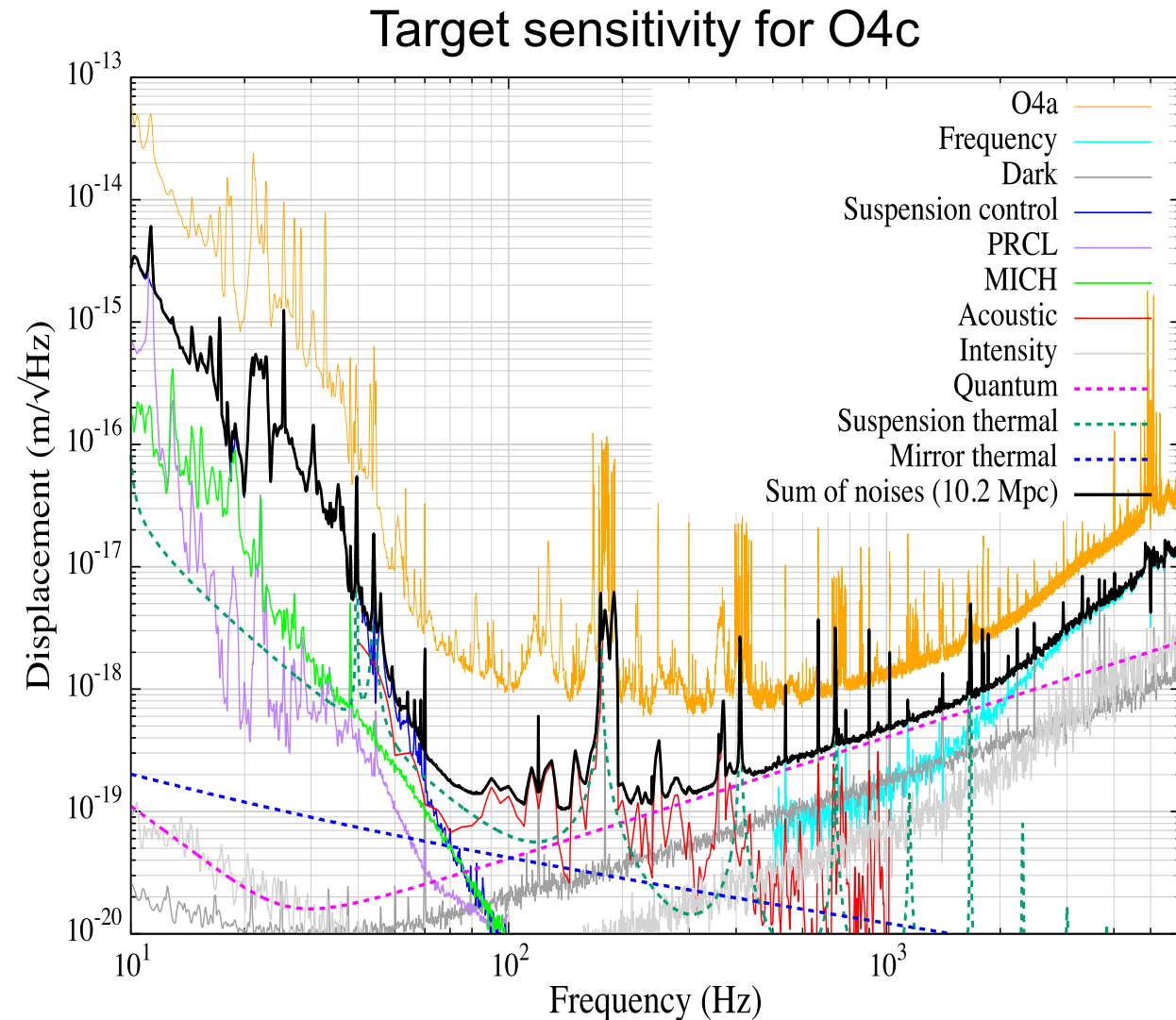

Control noise reduction

We changed the local damping control scheme:

Velocity damping → Narrow Band Damping (NBD)

Advantage and disadvantage of NBD:

- Possible to optimize the gains for each resonance
 - Avoid overdamping and unnecessary strong damping
- Lower noise in the observation band
- Difficult to critically damp the resonances
 - Residual Q factor of the resonance is sometimes high.
 - It affects the global control filters such as LSC and ASC.
- Low robustness
 - It easily becomes unstable when the suspension characteristics change, especially during cooling.

High-pass filter

Displacement



×

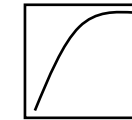

Roll-off filter

×

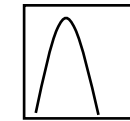
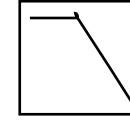

×

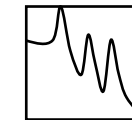

×



Displacement

×

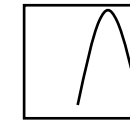

Band-pass filters

OMC PD dark noise

Two OMC transmission PDs have large electrical coupling, which changes in time.

We found two issues needed to be solved.

1. Bad ground connection for switching impedance in the pre-amplifier of OMC DC PDs.
2. Large electrical coupling from power supply cables, which was located near the signal cables.

By changing the cabling connection and separate the signal cables from power lines, the breathing noise around 100 Hz was drastically improved.

Comparison of quiet and noisy spectrum

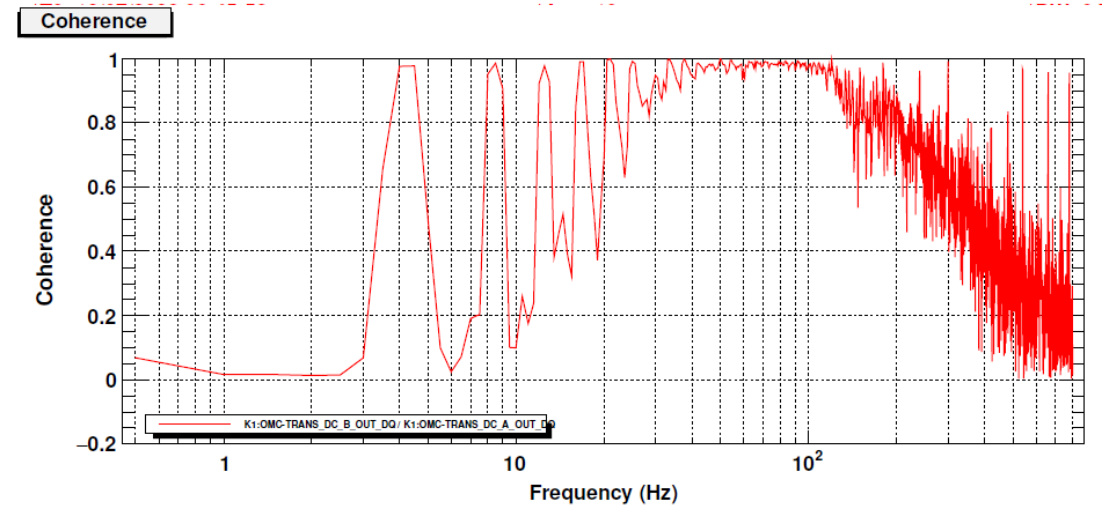
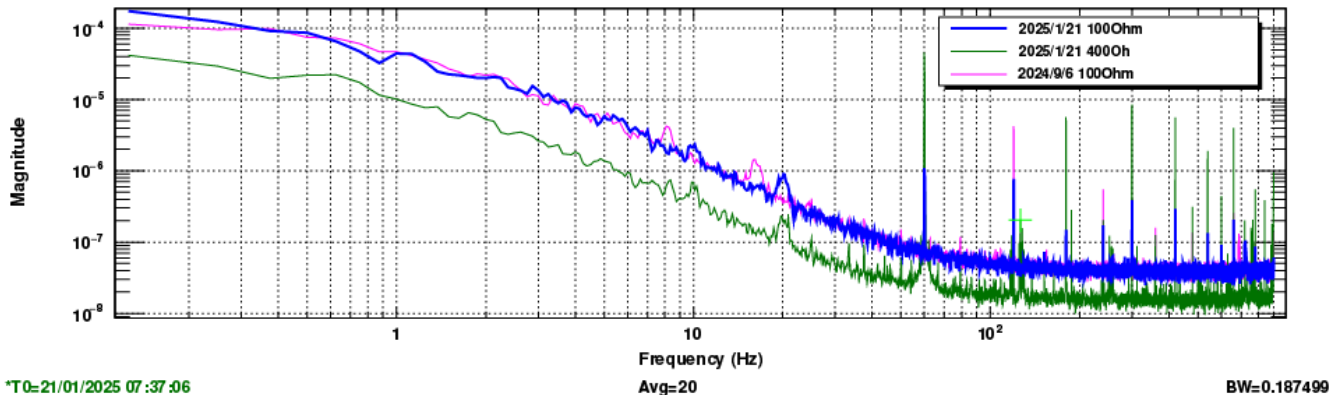
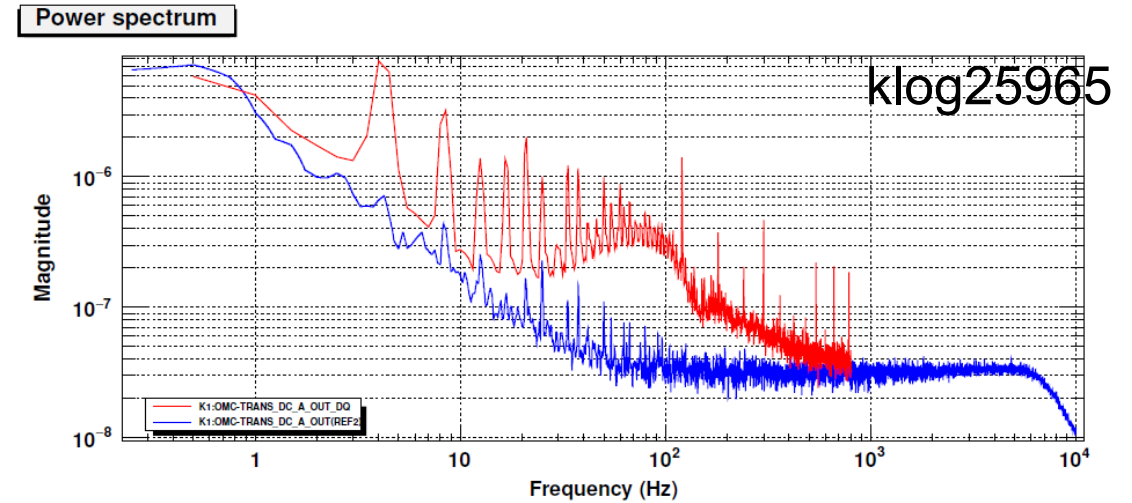

Acoustic noise (around OMC)

Several issues are found on OMC VIS:

- The overload caused the OMC VIS stack to malfunction.
- The OMC suspension resonances had not been damped.
- The OMC VIS stack resonances and the OMC suspension resonances had overlapped.
- The performance of vertical isolation is not good.

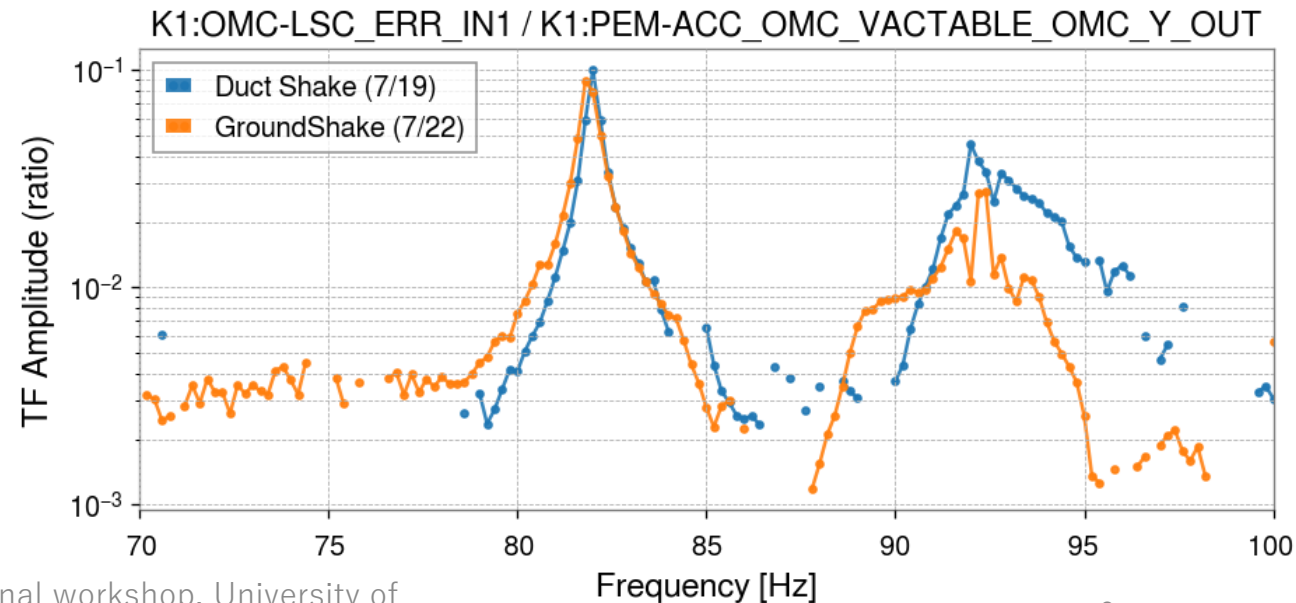
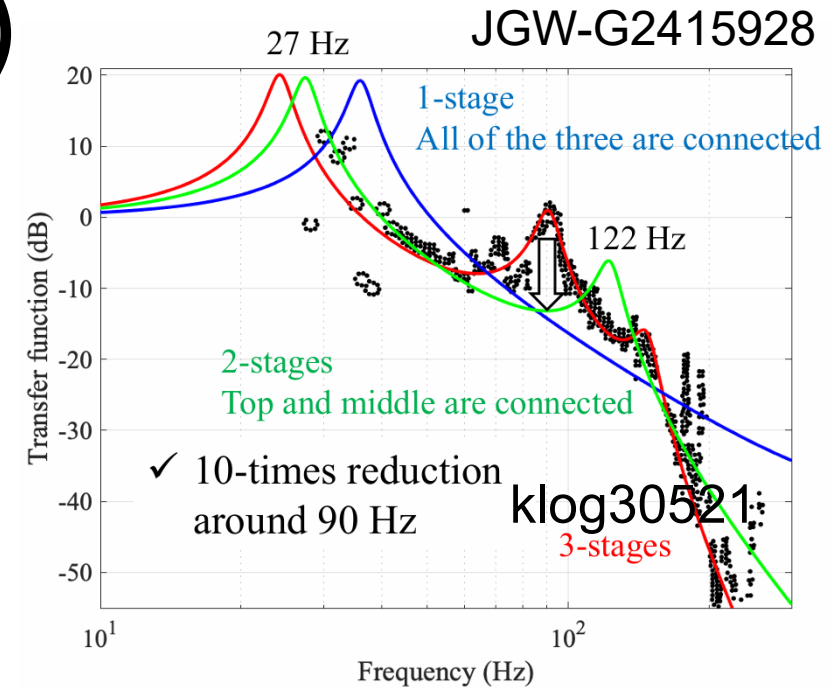
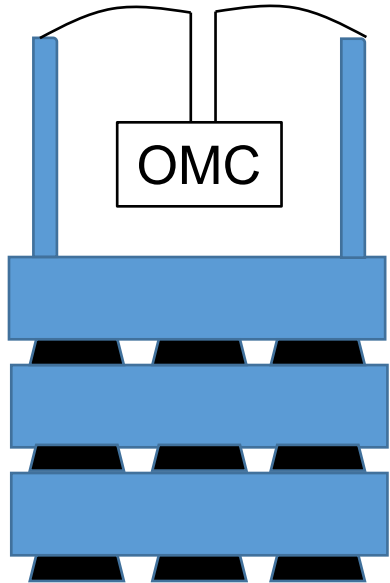
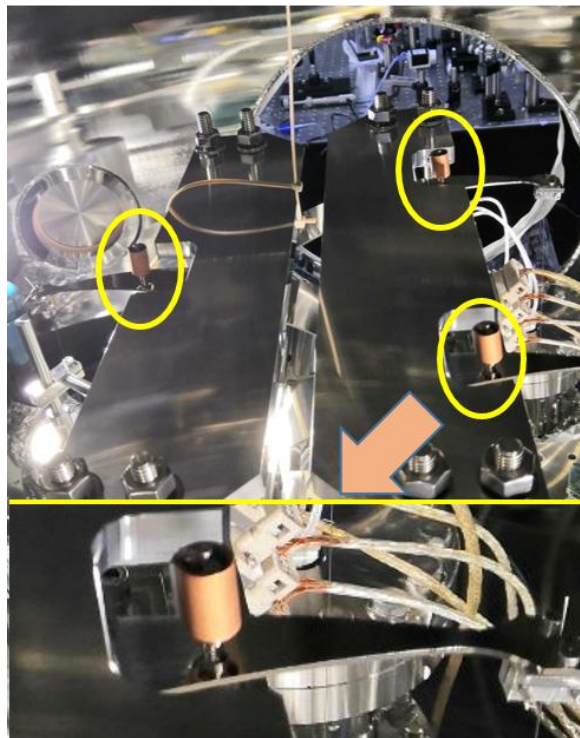

Acoustic noise (around IFI)

Issues around IFI:

- Two steering mirrors, which are not well isolated from the ground motion, are located after IMC.
- One of the fixed screws for STM2 was loose and the stability of the mirror mount becomes worse.

Tightening the screws on the mirror mount reduced the beam jitter generated at STM2 drastically.

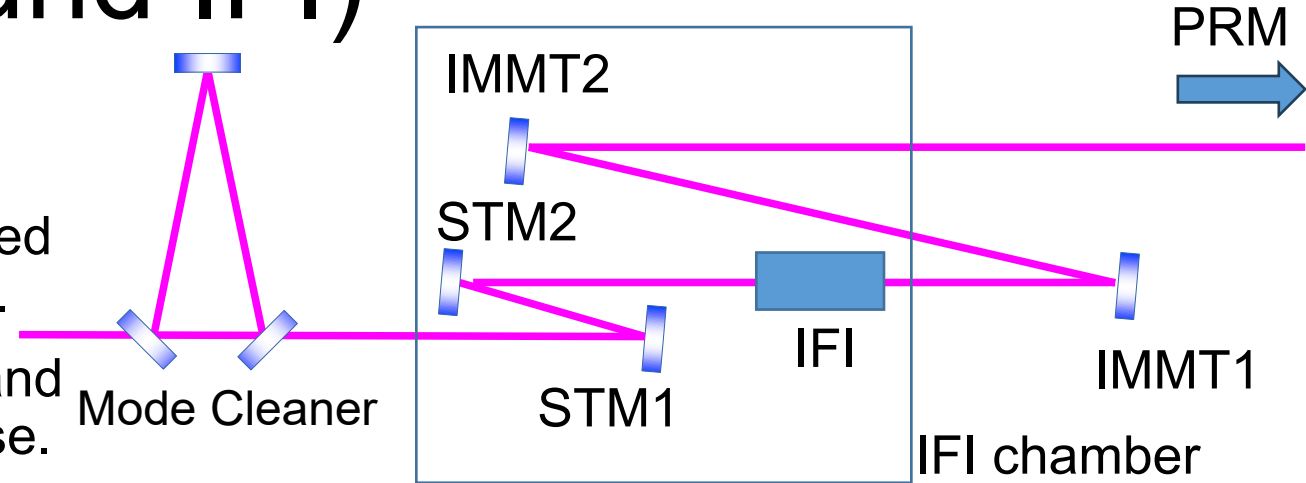

Spectrum of QPDs for beam jitter monitor

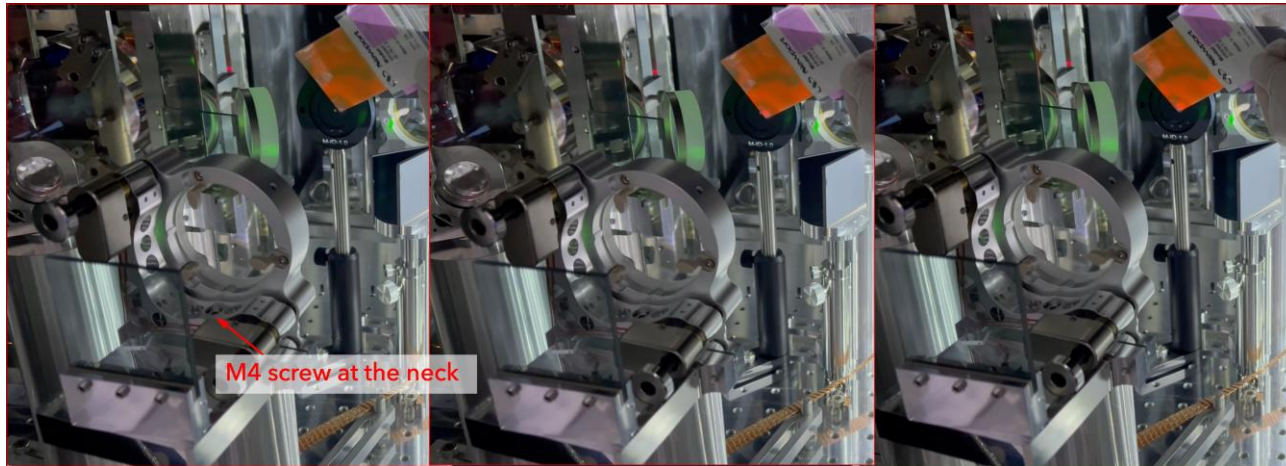

Pictures during tightening the screw

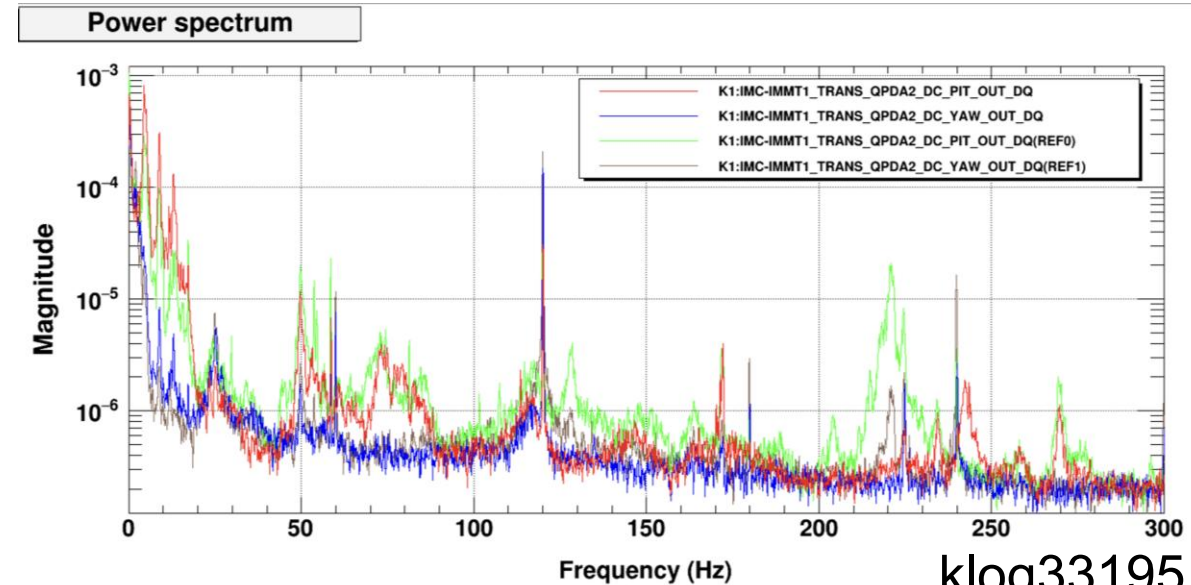

klog33195

Alignment Sensing and Control

Alignment sensing and control (ASC) was upgraded from O4a.

- WFS: IMC, Diff ETMs, Comm ETMs, BS, and OMC (beacon)
→ IMC, CHARD, DHARD, BS, PR3, and IMMT2
- ADS: PRM and IMMT2 → No ADS
- DC QPD: XSOFY and YSOFY → XSOFY and YSOFY
- BPC: ETMX and ETMY → ETMX, ETMY, and ITMY

Normalized transmission powers became more stable: improving stability and sensitivity

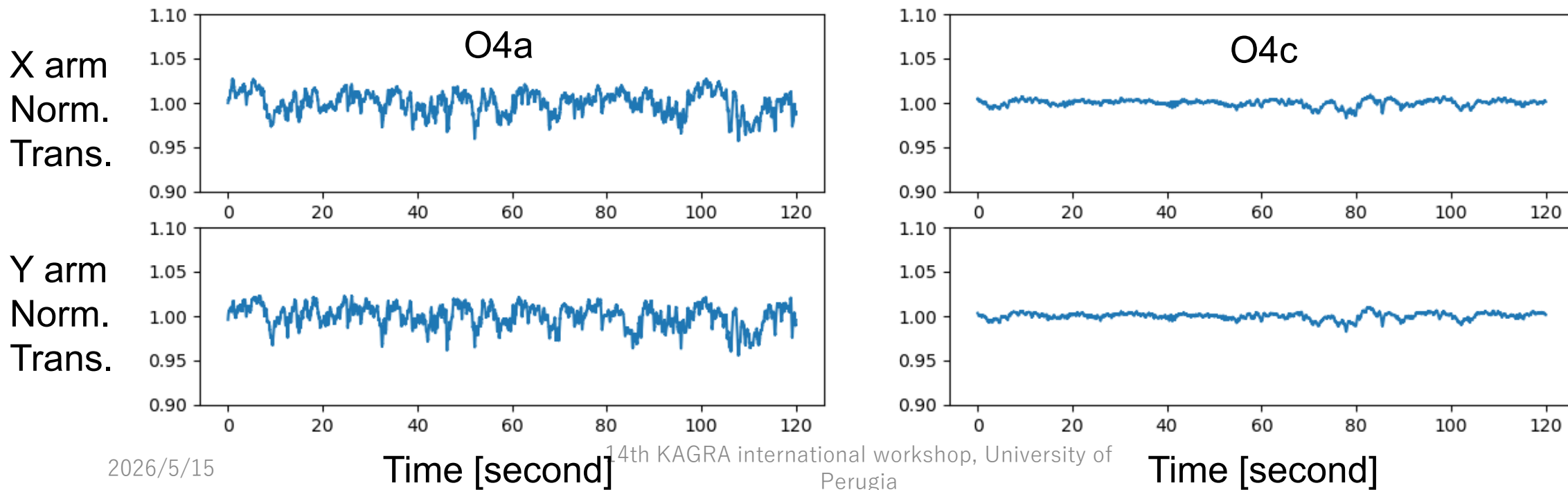

Sensitivity improvement

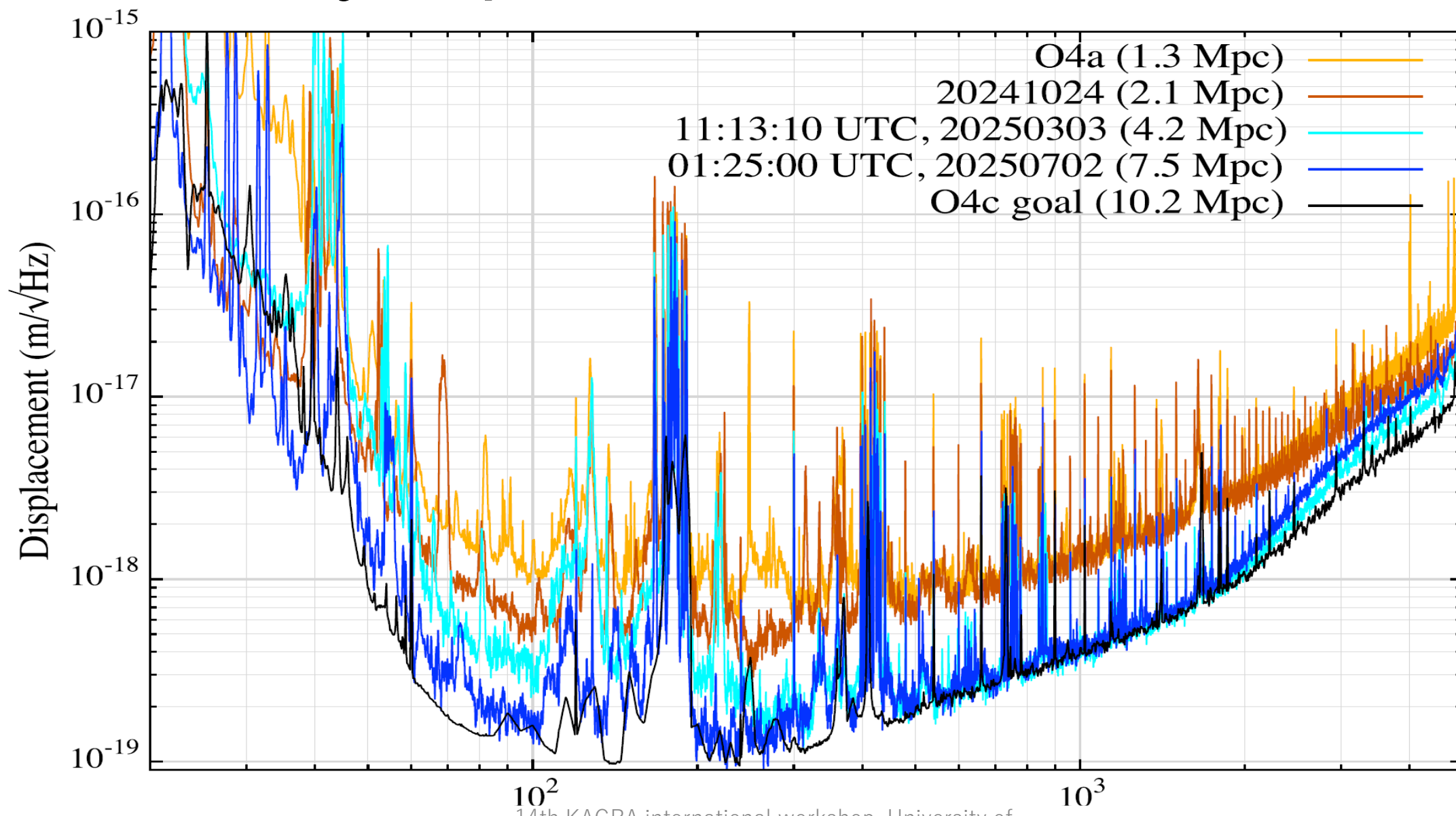

Status during KAGRA O4c

KAGRA configuration during O4c

Configuration: PRFPMI (AR coated SRM)

Laser power: 10.5 W @ IMC output

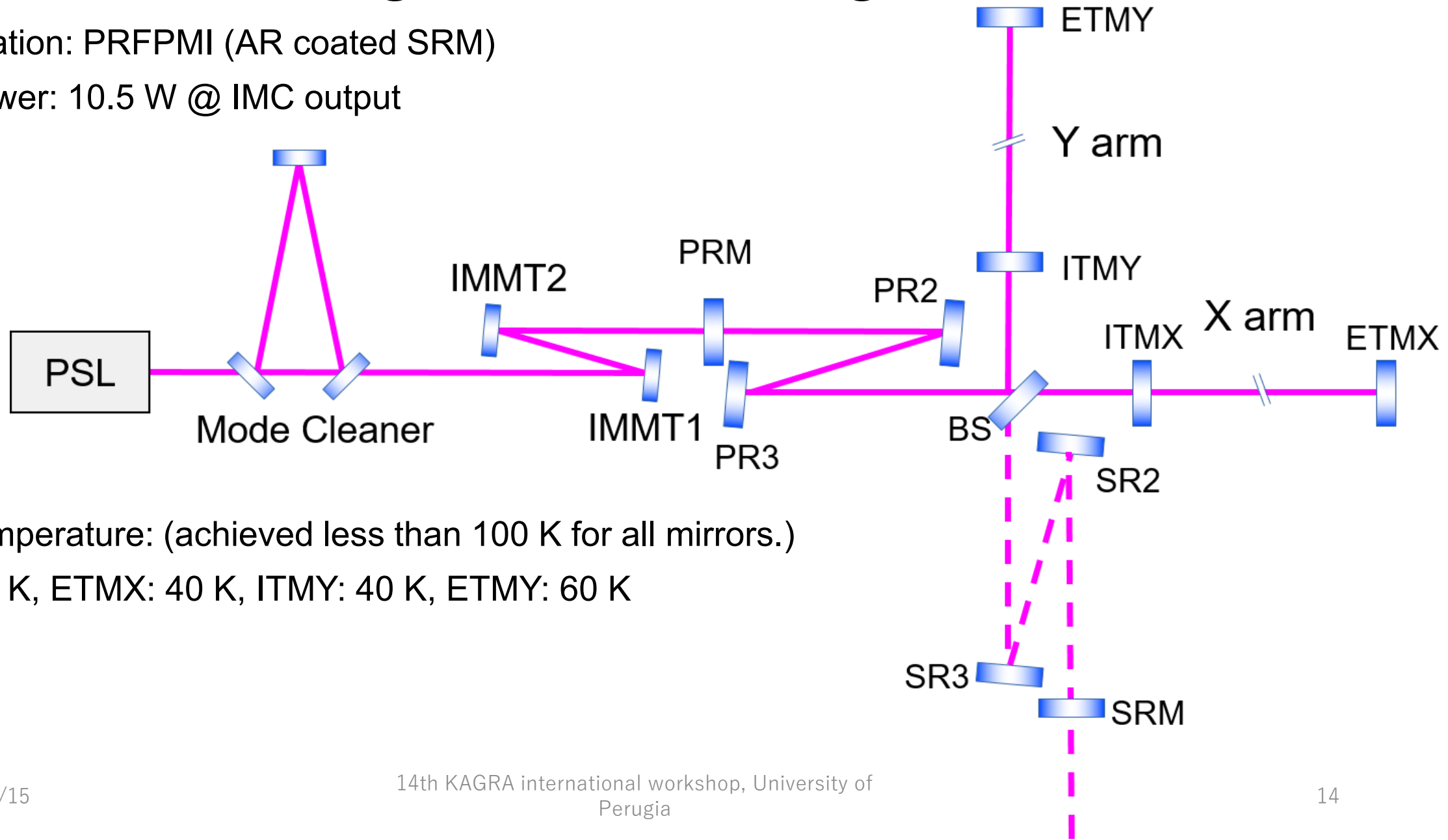

Mirror temperature: (achieved less than 100 K for all mirrors.)

ITMX: 90 K, ETMX: 40 K, ITMY: 40 K, ETMY: 60 K

KAGRA status during O4c: highlight

- KAGRA participated in the second block of the O4c observing run (from June 11 to Nov. 18), operating for the first two months and the final five days, while remaining offline for three months in between due to a malfunction in the main laser.
- The BNS range of 5–7 Mpc (maximum 7.5 Mpc) was achieved, which is five times better than the O4a sensitivity (1–1.5 Mpc).
- The duty factor during this period registered at 20.3%, and the reasons for the offline were primarily attributed to the laser troubles and substantial seismic activity.

BNS range evolution, obtained from the [GWISTAT public website](https://gwstat.ligo.org/)

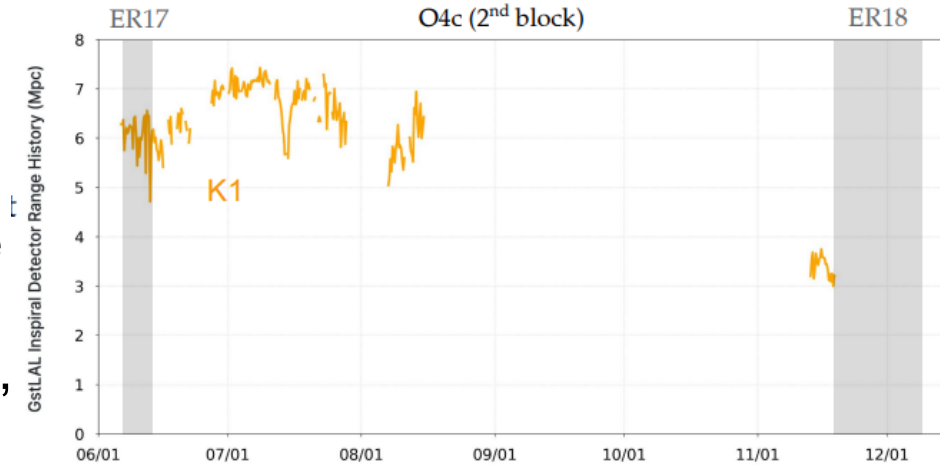

JGW-G2617266-v1

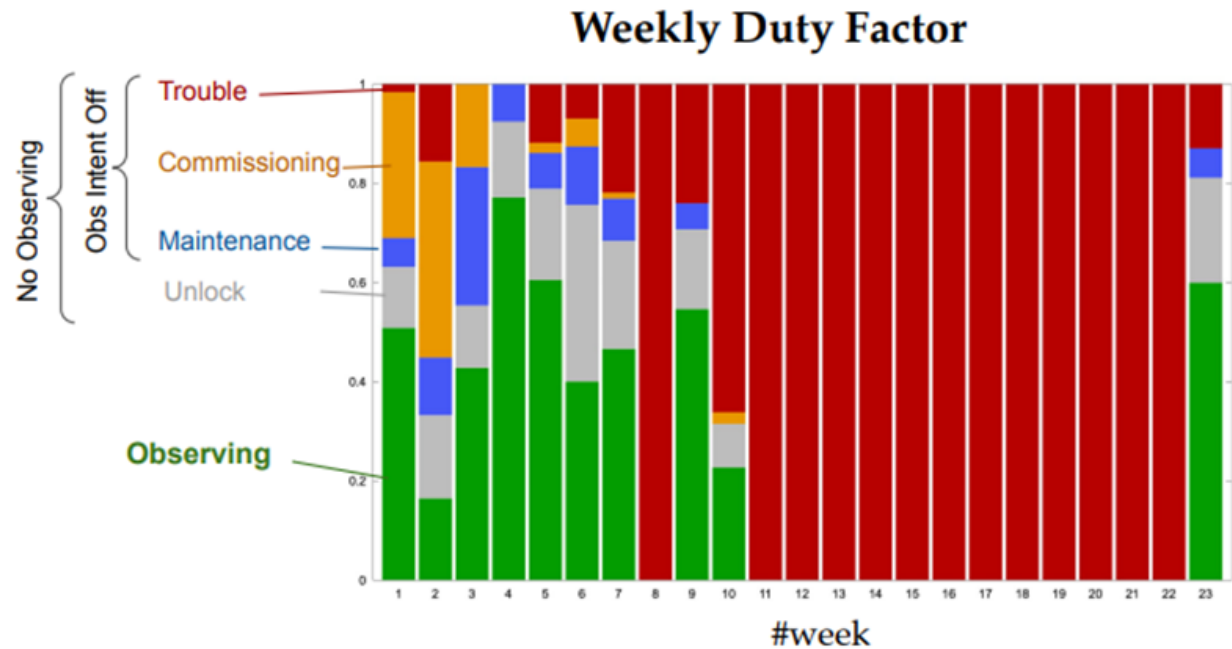
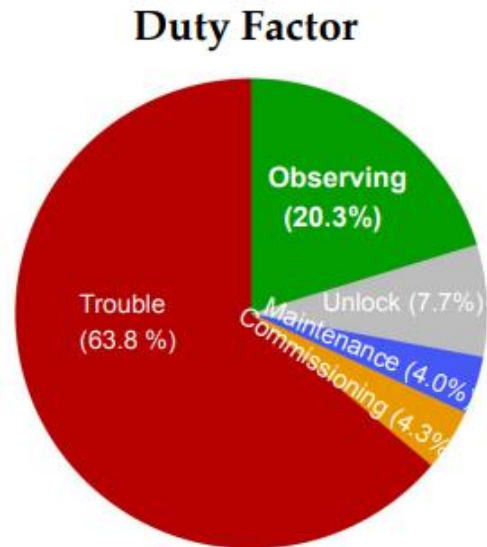

What happens with long-term cryogenic operation

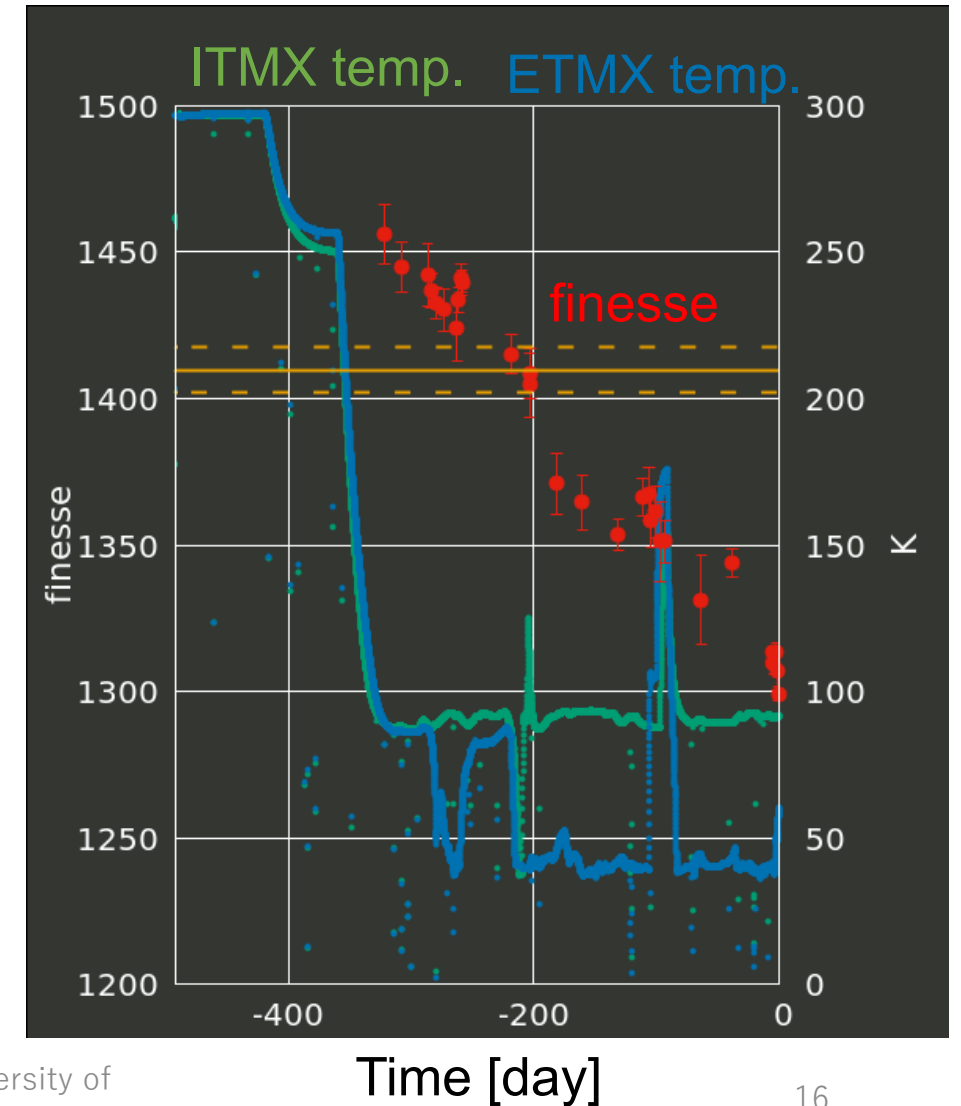
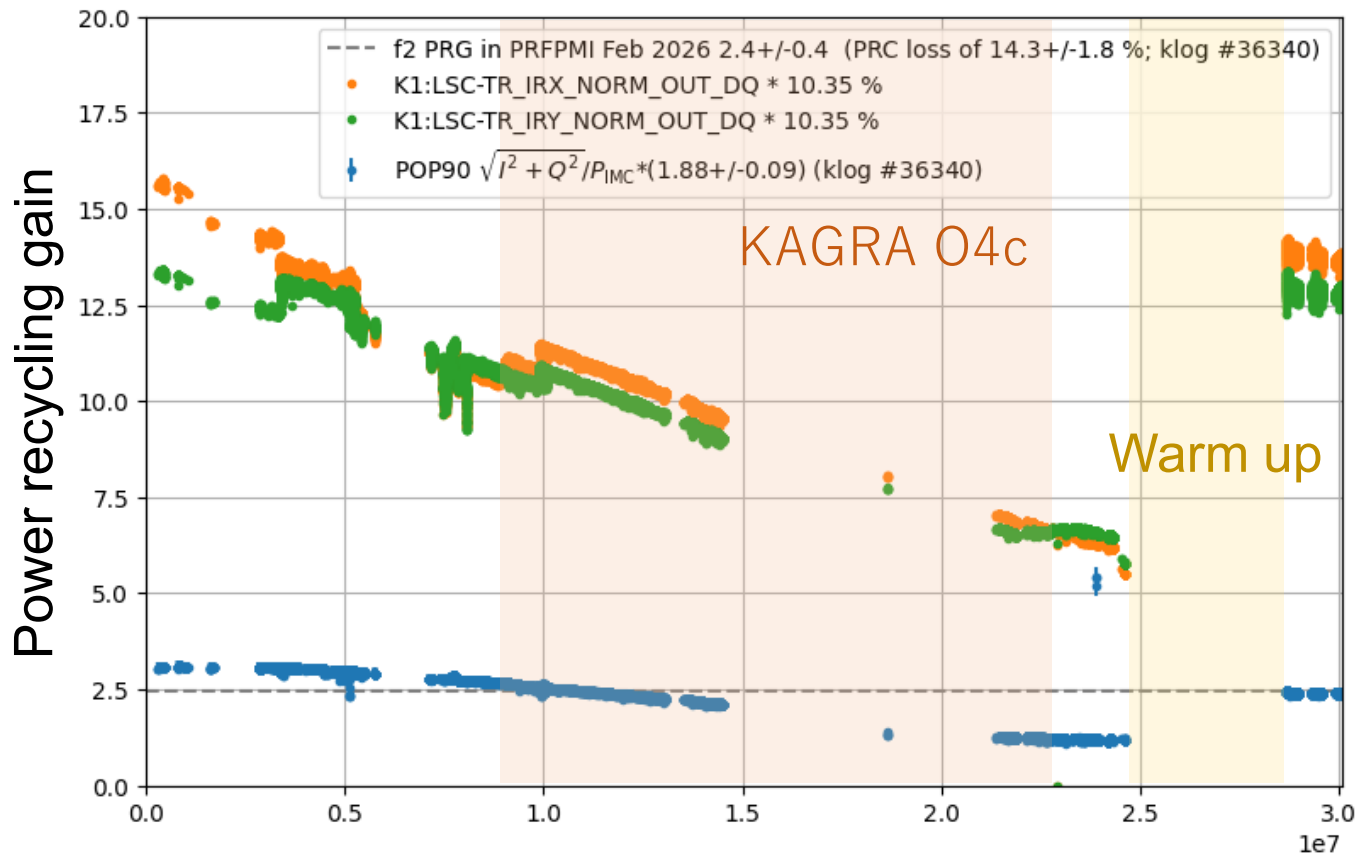

Discussion on finesse and PRG reduction

JGW-G2617195

- Finesse and PRGs for both carrier and sidebands are reduced in time.
- Since they kept high just after cooling mirrors, the reason of the reduction should not be caused directly from the temperature reduction.
- They were gradually reduced in time, so it is likely due to forming residual gas layers (frost) on the mirror surface.
- The PRG reduction rate is consistent with the formation of water molecules on the mirror surfaces (klog34903).
- To explain the finesse and PRGs reduction at the same time, the cavity reflection doesn't seem to reduce by increasing loss but increasing transmission of ITMs.
- After warming up the mirrors, PRGs and finesse were recovered (not fully but the reason is not clear).

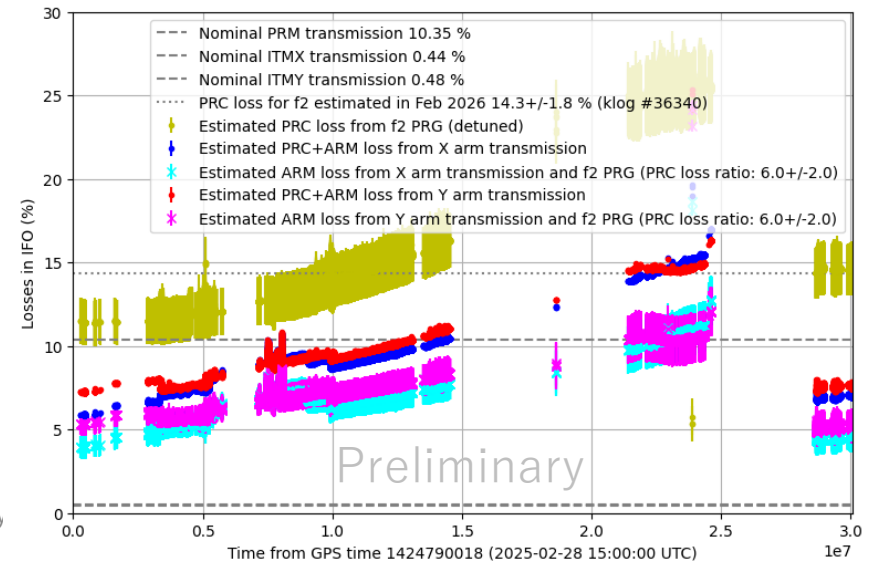
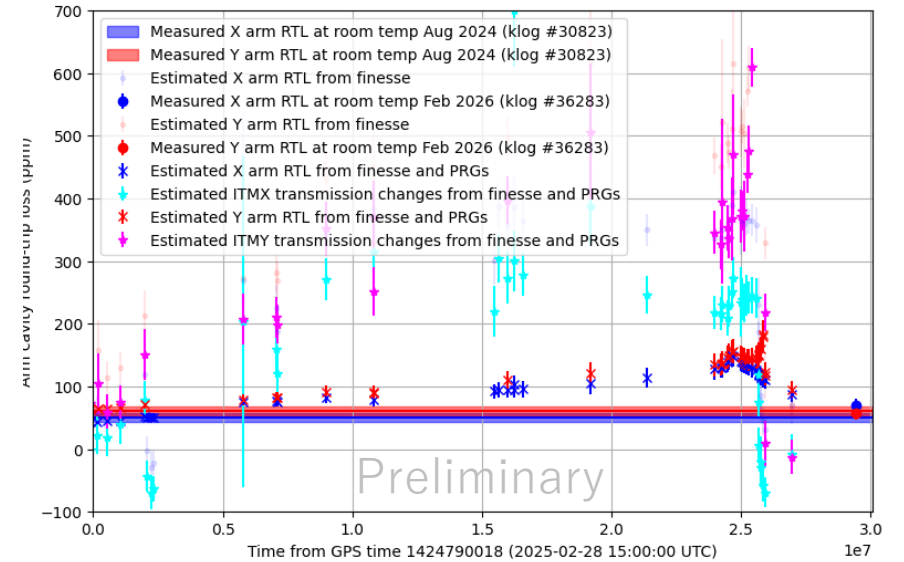

Toward IR1 and O5

Latest IGWN observing plan

Both LIGO detectors will be observing in IR1, and Virgo and KAGRA will join as they are available.

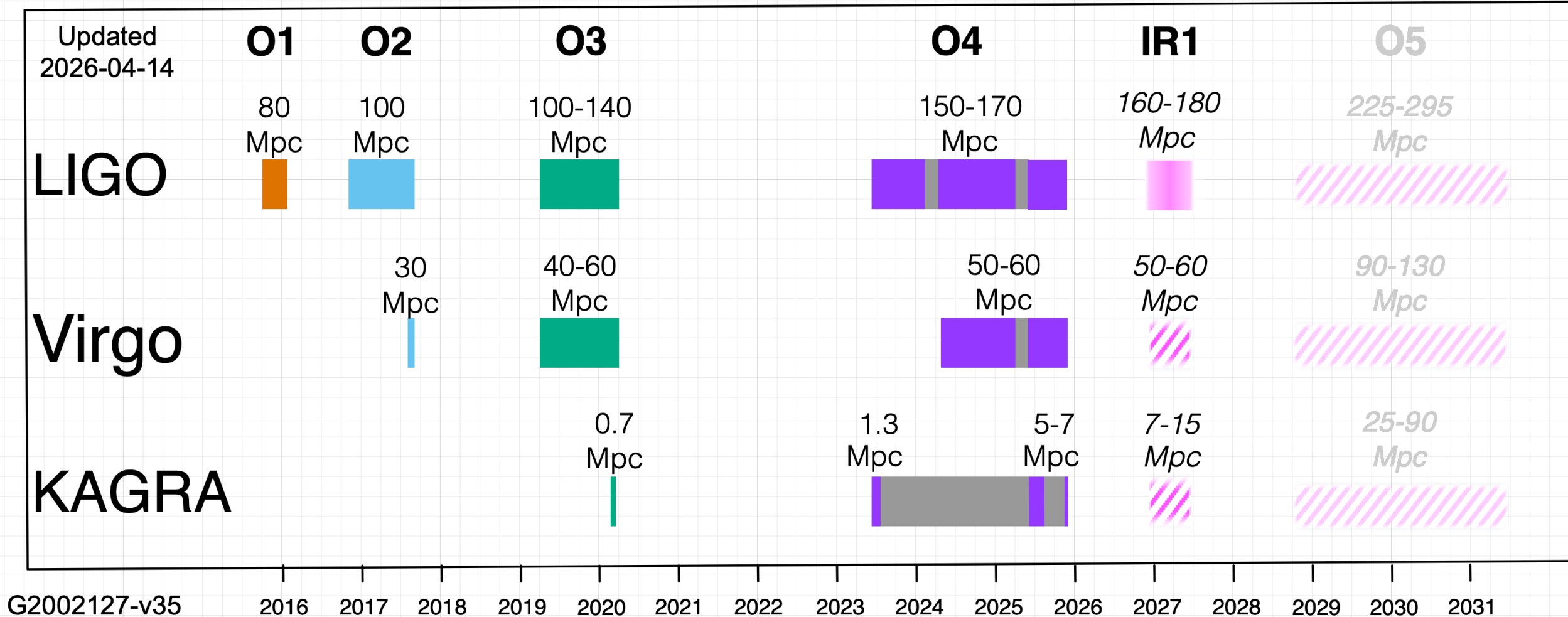

O5 target sensitivity

- Local control noise reduction
 - Optimization of controls
- Shot noise reduction
 - Laser power increase
 - Achieving RSE configuration
- Thermal noise reduction
 - Cooling mirrors to 30K
 - Beam centering for P2L coupling reduction
- Beam jitter and acoustic noise reduction
 - ITM replacement
 - IFI modification
 - OMC VIS upgrade
 - Rigid beam position controls on ITMs
- Frequency noise reduction:
 - ITM replacement
 - Control optimization

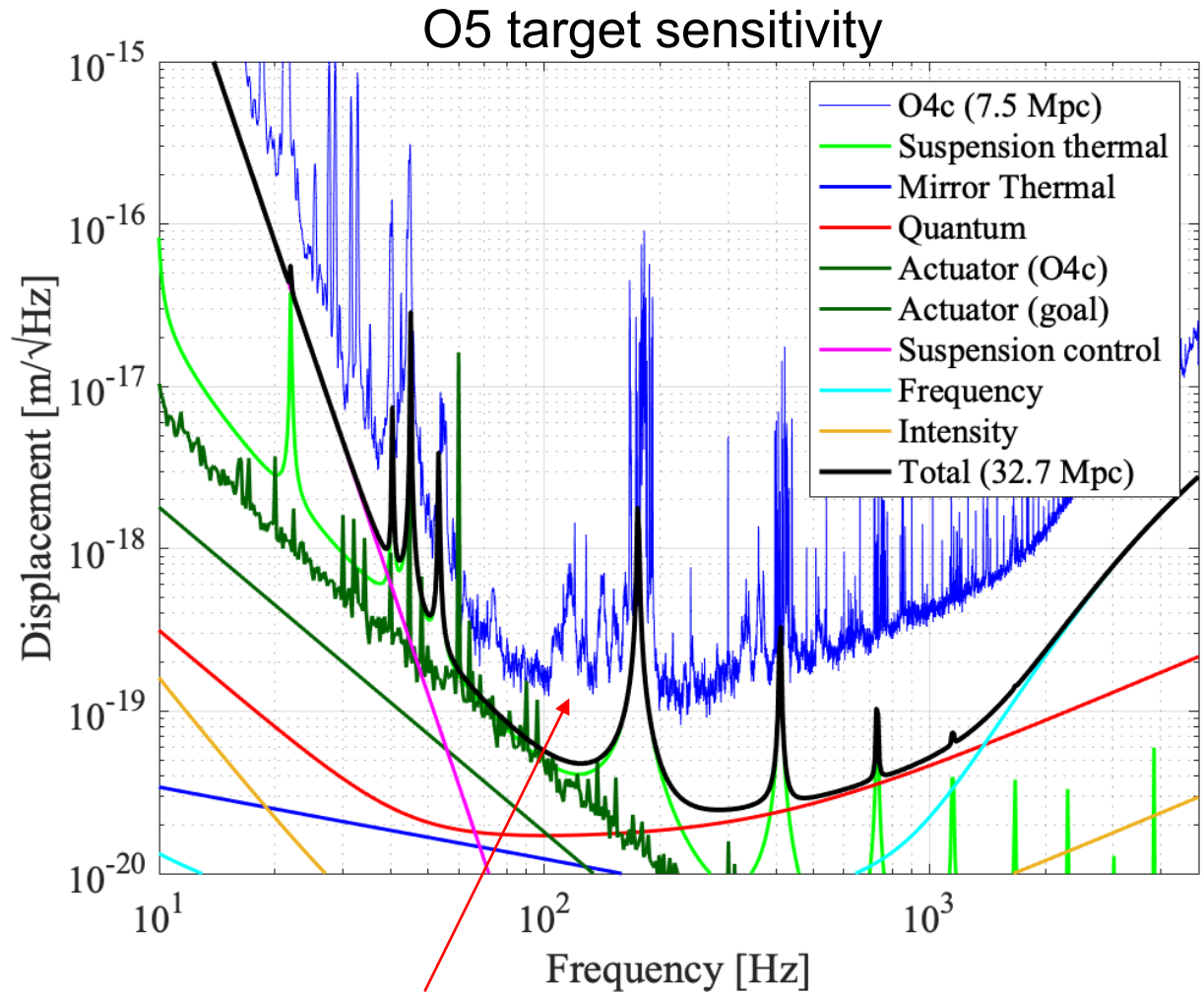

Beam jitter noise mitigation is challenging

Toward O5 schedule

260508
Shorter KAGRA IR1 schedule

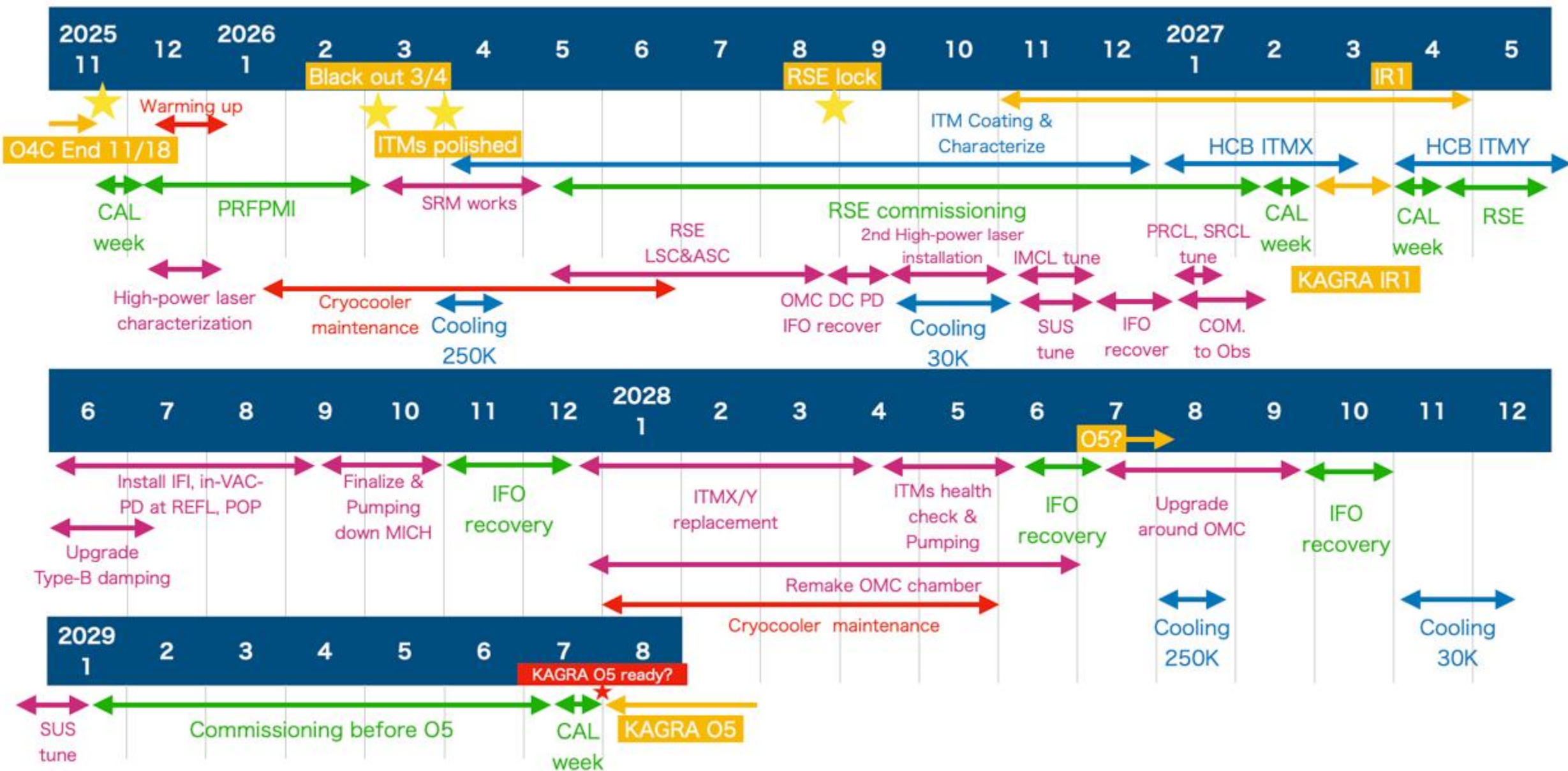

RSE commissioning

- In the case of the observing runs O3 and O4, KAGRA adapted the PRFPMI configuration. However, the objective is to utilize the Resonant Sideband Extraction (RSE) technique to enhance the sensitivity for IR1 and O5.
- In 2020, a two-month commissioning period was undertaken to achieve RSE configuration; however, the locking of the interferometer was not successfully achieved at that time.
- Main problems at that time were:
 - Poor vibration isolation performance
 - Poor experience of Alignment Sensing and Controls (ASC)
- During the commissioning phase of the O4 observing run, KAGRA implemented inertial damping controls for the test mass and BS suspensions. This implementation enhanced their vibration isolation performance. In addition to that, ASC with Wave Front Sensing (WFS) was employed for all the relative degrees of freedom of the interferometer alignment, which could not be achieved during the observing run O3.
- The characterization process for the SRC and DRMI in achieving the RSE configuration has commenced this month.

New ITM production

Current ITMs have two main problems:

1. Different transmissivity: Low common mode reduction ratio (CMRR)
2. Large inhomogeneous birefringence: low MICH contrast for sidebands

JGW-G2617259

We found better crystals with homogeneous birefringence.

Strategy for better ITMs:

- Cut out the crystal in the optimal direction
- Coating at the same time

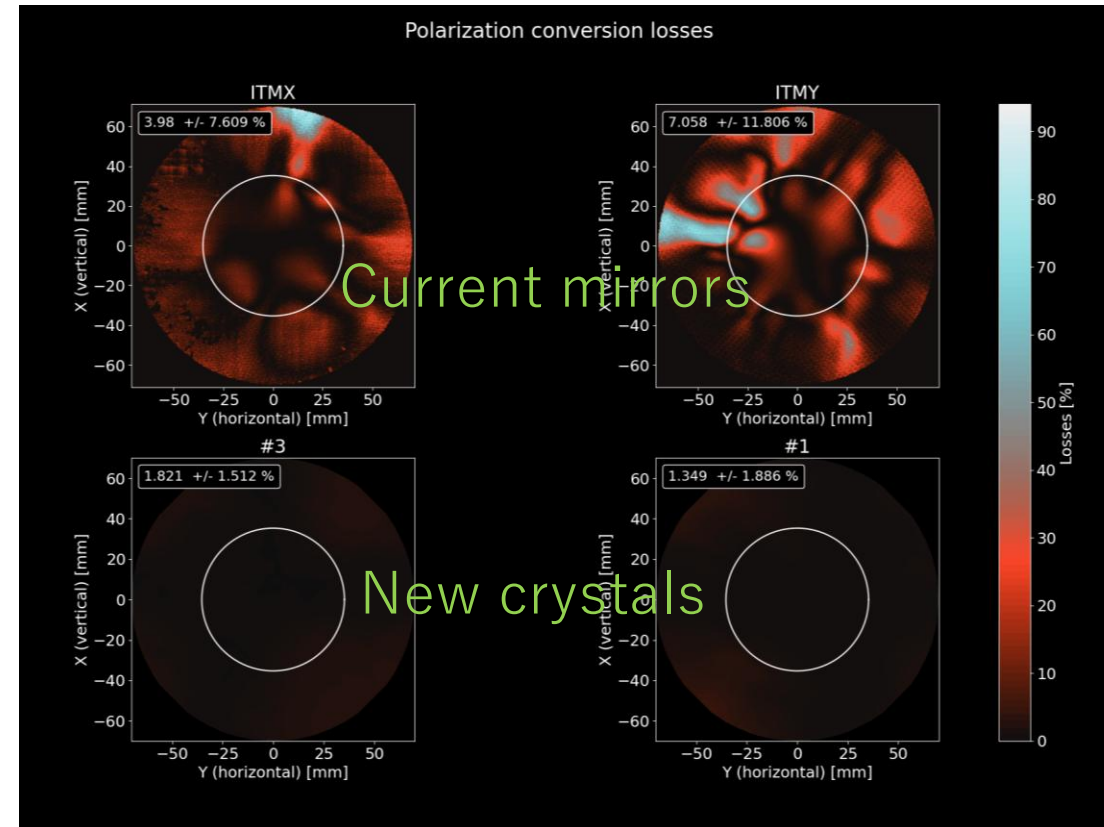
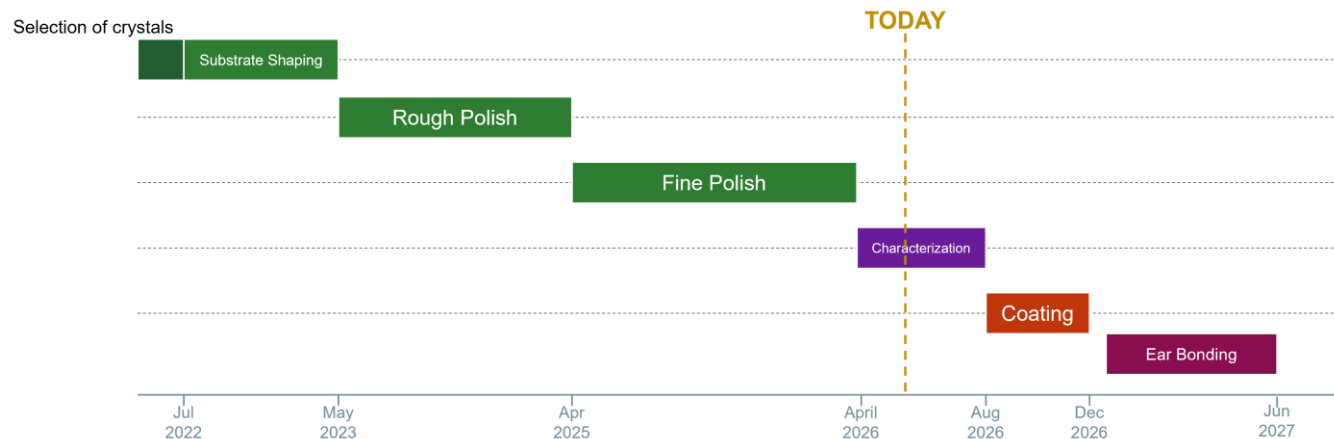

IFI upgrade

Current IFI problems:

1. Due to the poor beam separation due to CWP, we need two steering mirrors, which are fixed on the optical table, after IMC.
2. Scattered light from the IFI optical components

Our strategy for new IFI: Using KTF + TFPs

- Enable to enlarge beam separation
- Enable to reduce a number of optics.

We purchased a commercial FI with KTF crystal, which satisfies requirements for KAGRA O5, except for the aperture size and start testing it.

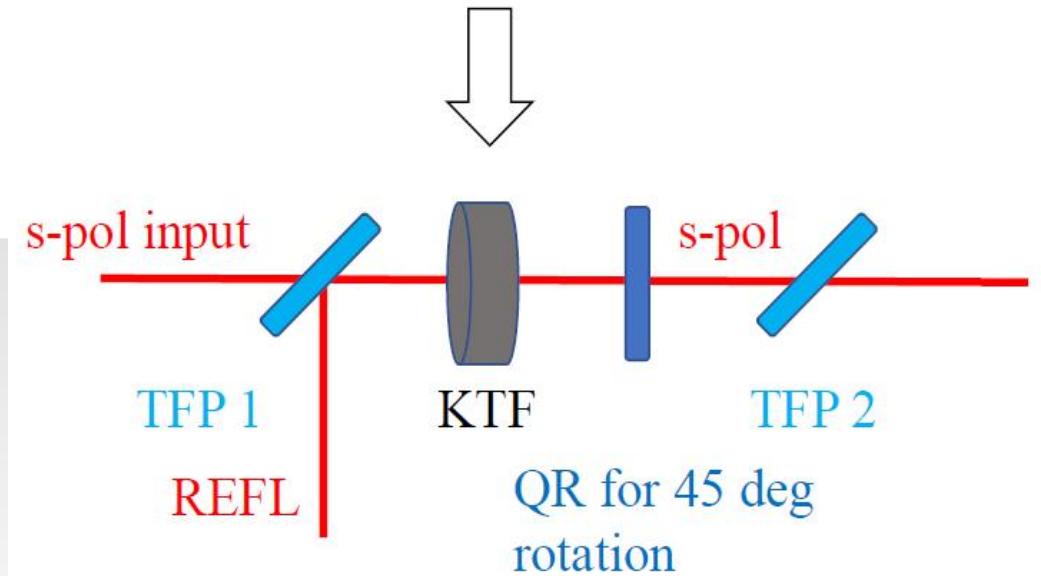
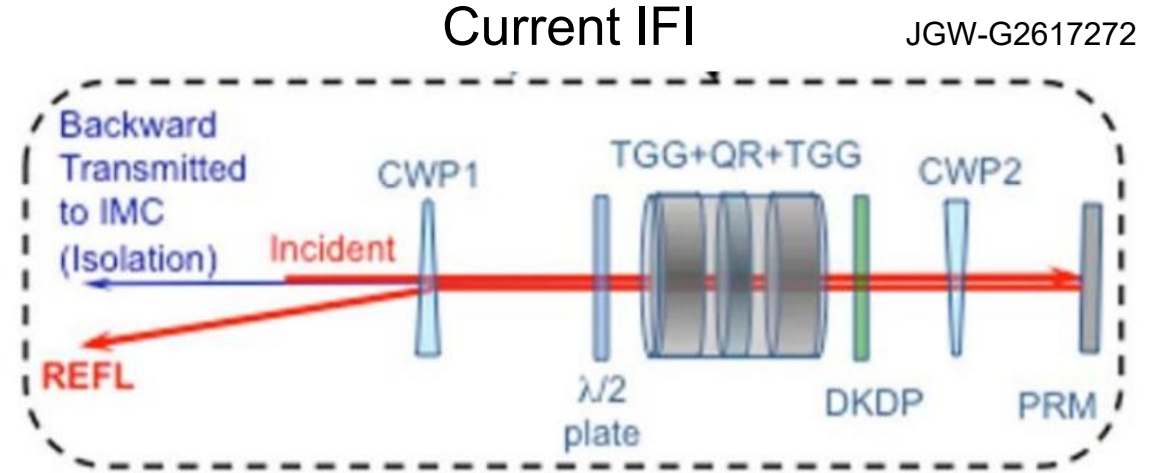

New IFI plan

OMC VIS upgrade

- We found vibration of OMC couples to DARM signals via OMC length fluctuation.
- The estimated coupling factor from OMC length fluctuation to DARM is consistent with the theoretical expectation, OMC length fluctuation itself should be mitigated.
- Currently, OMC is located on the optical table with vibration isolation stacks but the vibration isolation doesn't seem sufficient, especially for vertical motion

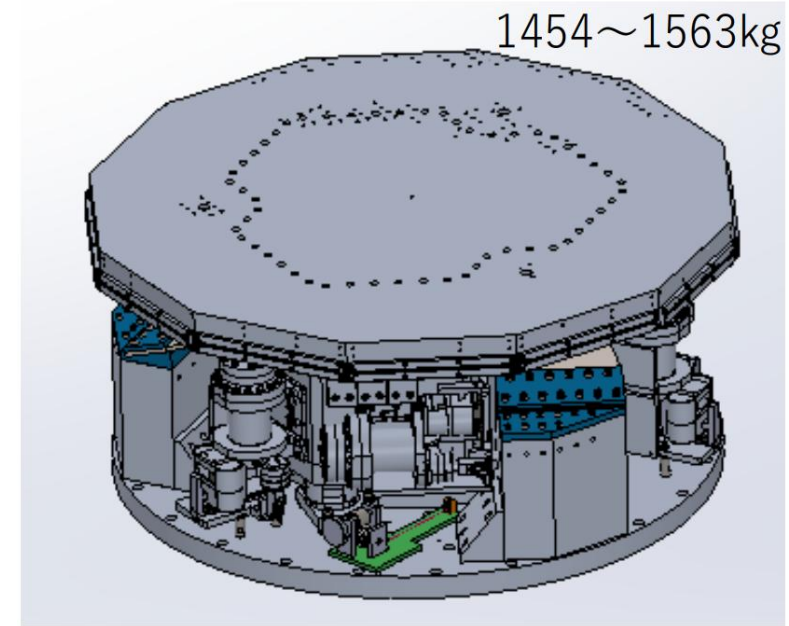

JGW-G2617307

OMC-VIS

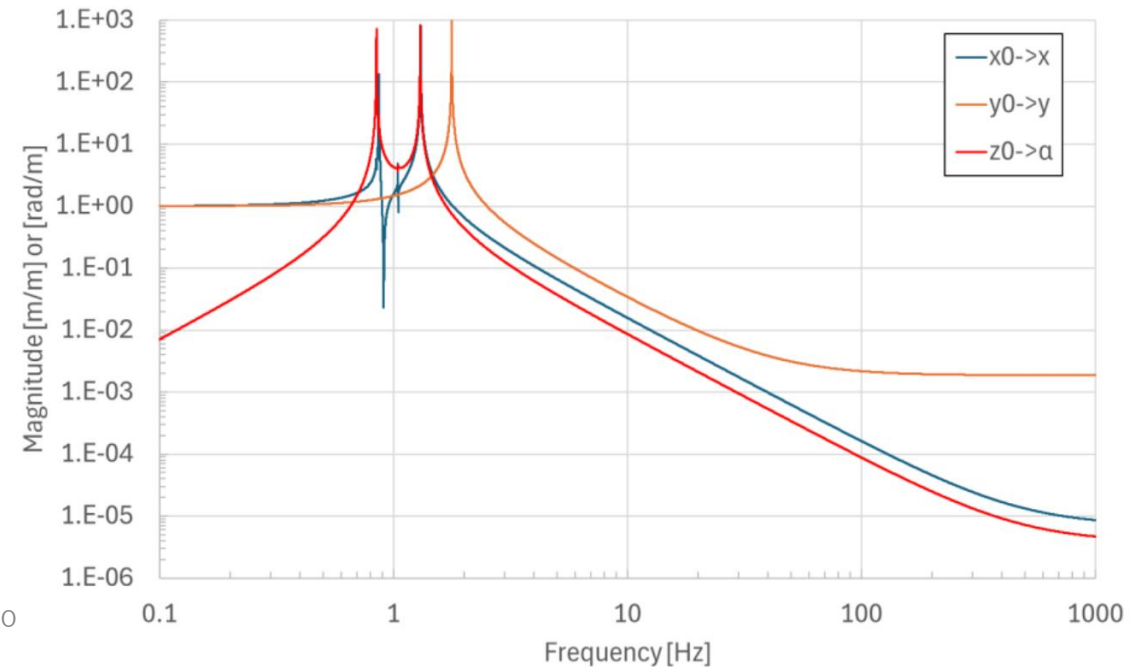
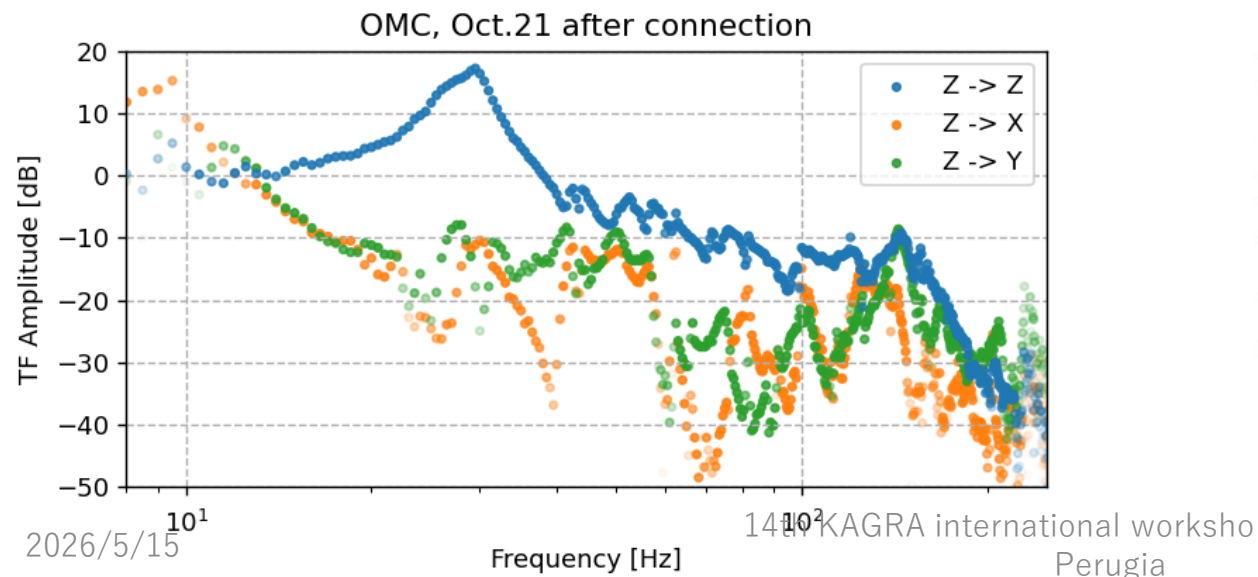

Other plans for upgrade

Cooling system upgrade: (Takayuki's talk)

- Once cooling system has a trouble, it spoils our commissioning time for 1-2 months. It is therefore very important to make the system more robust.
- Even without serious trouble, formation of the frost on the mirrors degrades the interferometer performance. The quick defrosting system should be considered.

Better sapphire suspension: (Munetake's talk)

- No improvement to the sapphire suspension was assumed for the current O5 target sensitivity. However, improvements to the sapphire suspension, particularly the Q-factor of the sapphire fibers, could enhance the sensitivity of KAGRA by a factor of 2–3.

Summary

- KAGRA participated in the second block of O4c
 - The first observing run with all four detectors operated at the same time.
 - KAGRA maximum sensitivity is 7.5 Mpc.
- Many lessons learned from the observing run:
 - The first operation with all sapphire mirrors cooled down below 100 K.
 - Gradual PRG reduction in time was first measured.
 - The degradation seemed due to frosting on the mirrors, which causes the transmissivity increase of input test masses.
- KAGRA proceeds commissioning and upgrade for IR1 and O5.
 - RSE lock trial
 - New ITM production
 - New IFI test
 - New OMC VIS
 - Others