



Study of Multi-messenger Science Scenarios with CTAO and Gravitational Wave Interferometers

Speaker:
Tobia Matcovich

Supervisors and collaborators:
Stefano Germani
Sara Cutini
Paolo C. Orestano

Compact Binary objects coalescence:

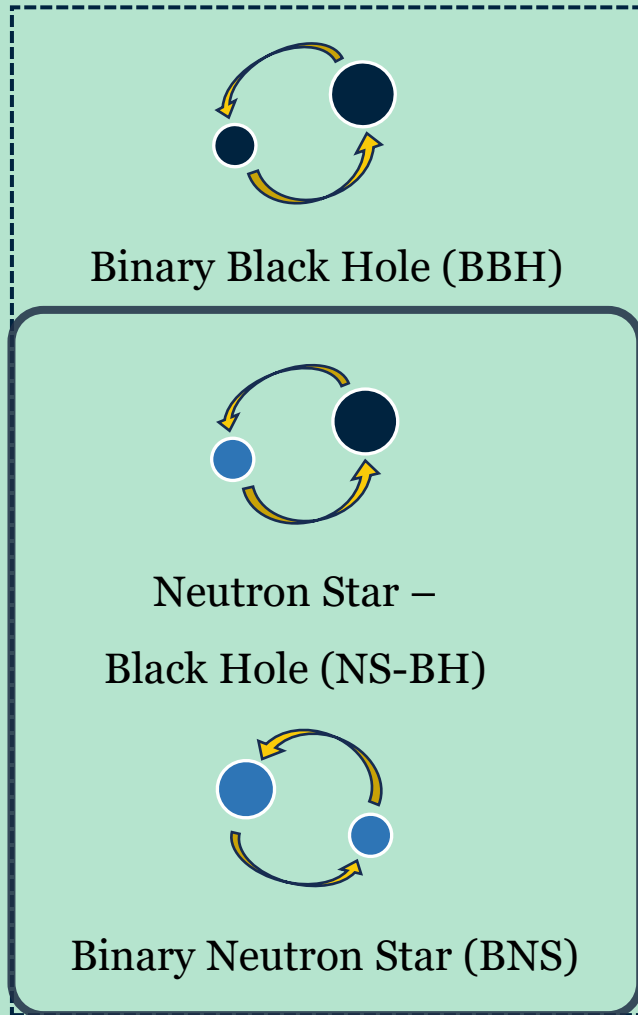

Merger parameters

Spins

NS Equation of State (EoS) or λ

R_{ISCO}

d_{tidal}

mass1 & mass2

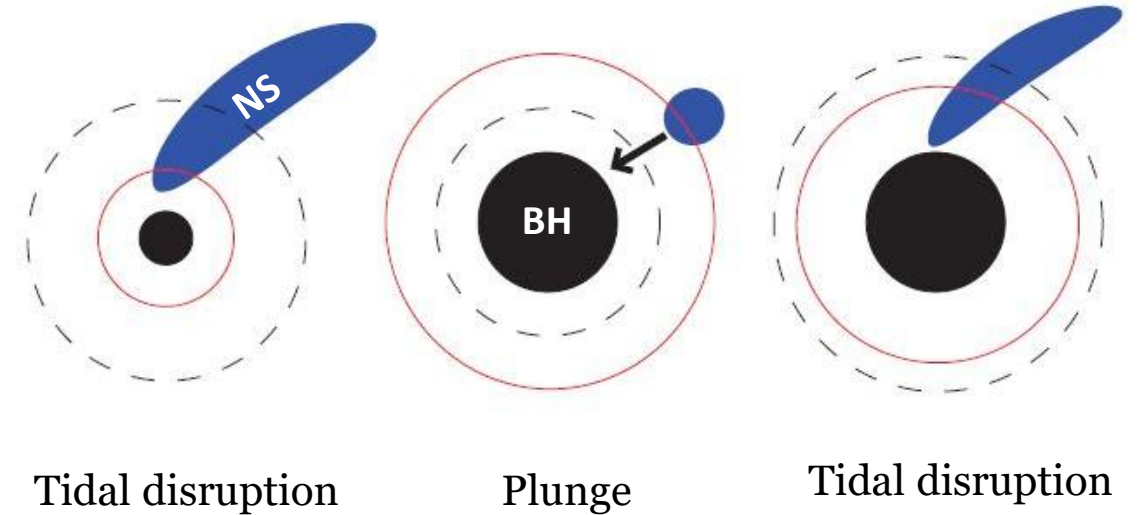

Compact Binary objects coalescence:

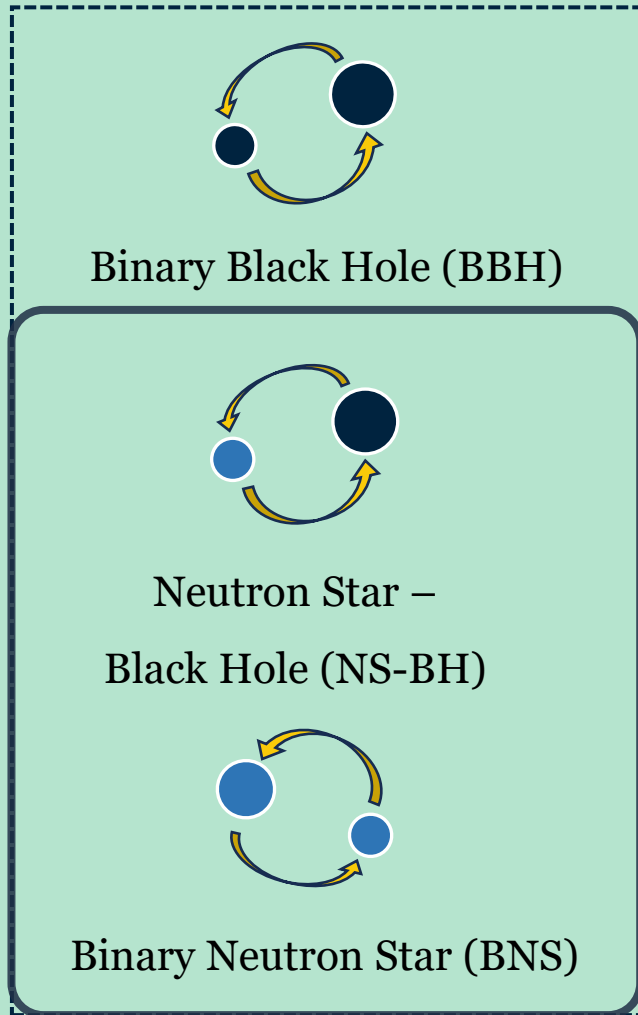

Multi-messenger
Astrophysics

1) Gravitational Wave signal

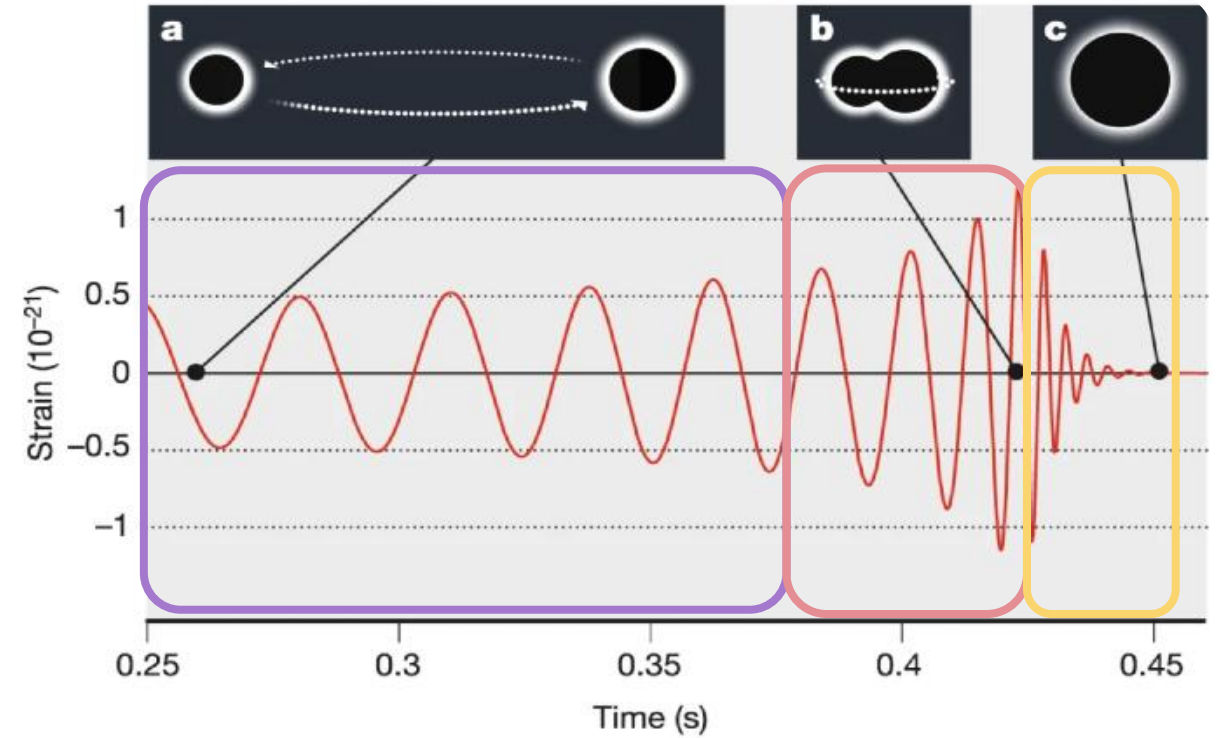

*Formation and
inspiral*

Ringdown and post-
merger phase

Merging phase

2) EM counterpart: Different emissions

- Relativistic jet
- Dynamical ejecta
- Wind ejecta

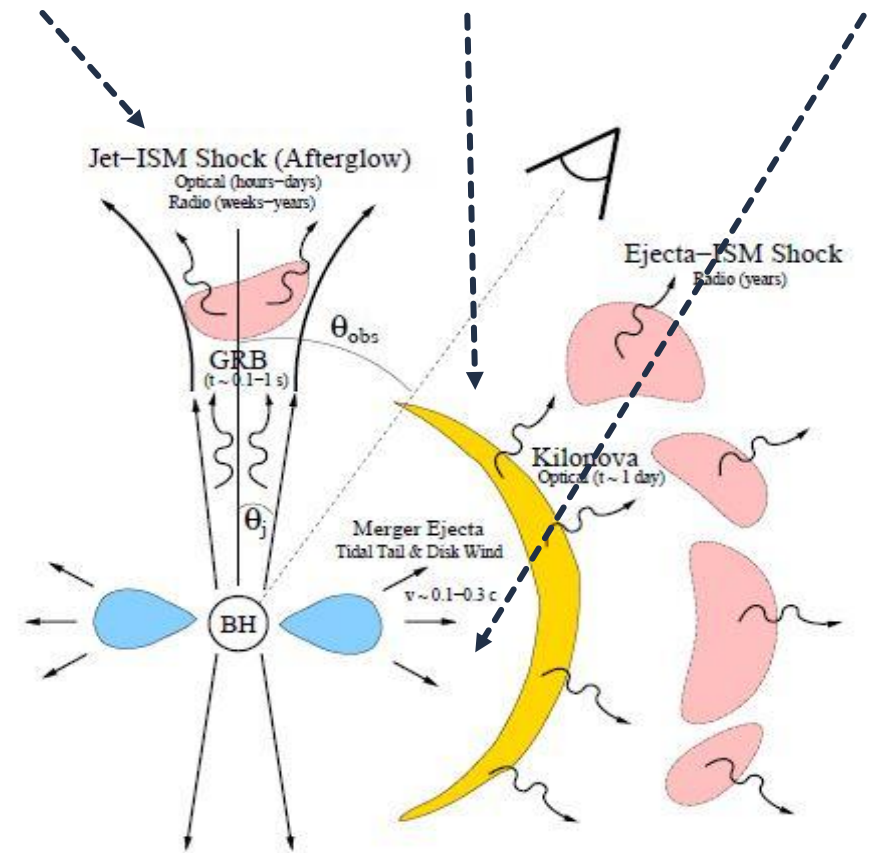

2) EM counterpart: Different emissions

- Relativistic jet
- Dynamical ejecta
- Wind ejecta

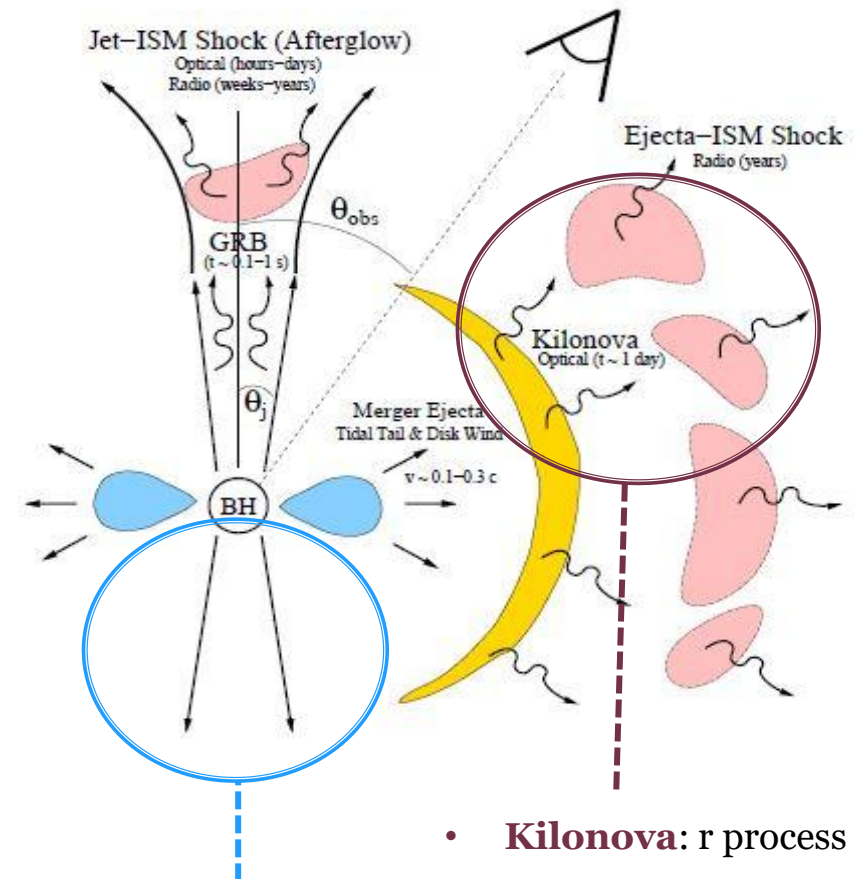

- **Kilonova:** r process
- **Gamma-Ray Burst:** Prompt and Afterglow emission

Mass Remnant

Prompt emission

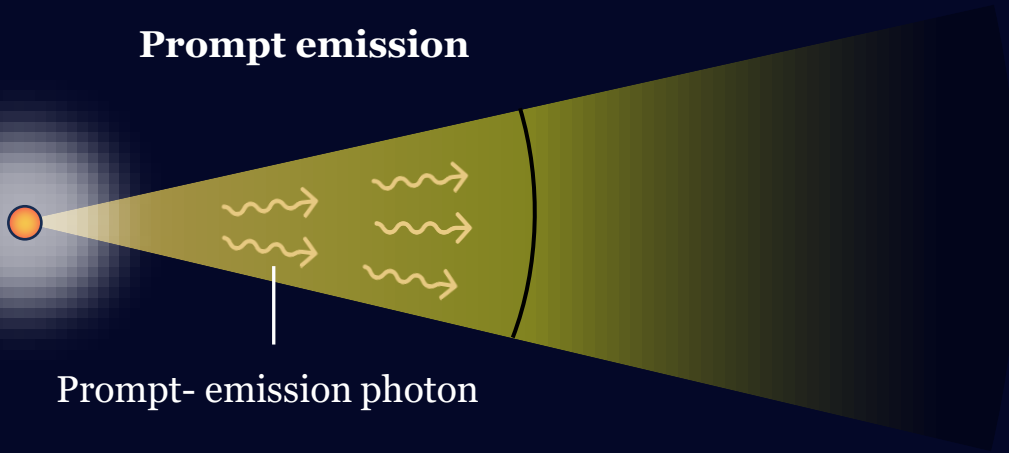

Prompt- emission photon

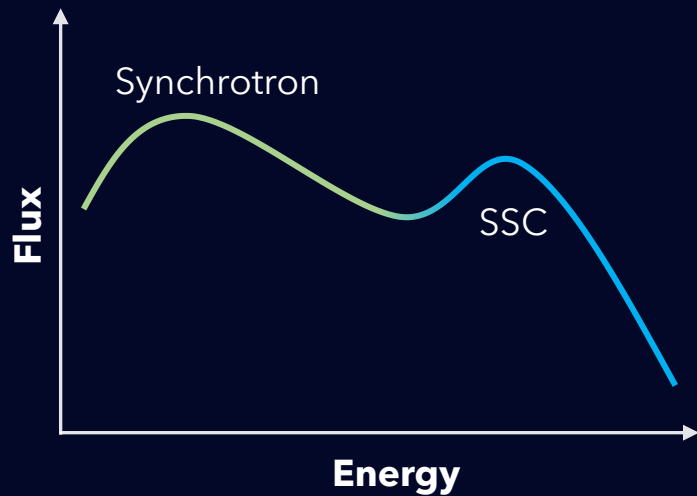

2) EM counterpart: Different emissions

- Relativistic jet
- Dynamical ejecta
- Wind ejecta

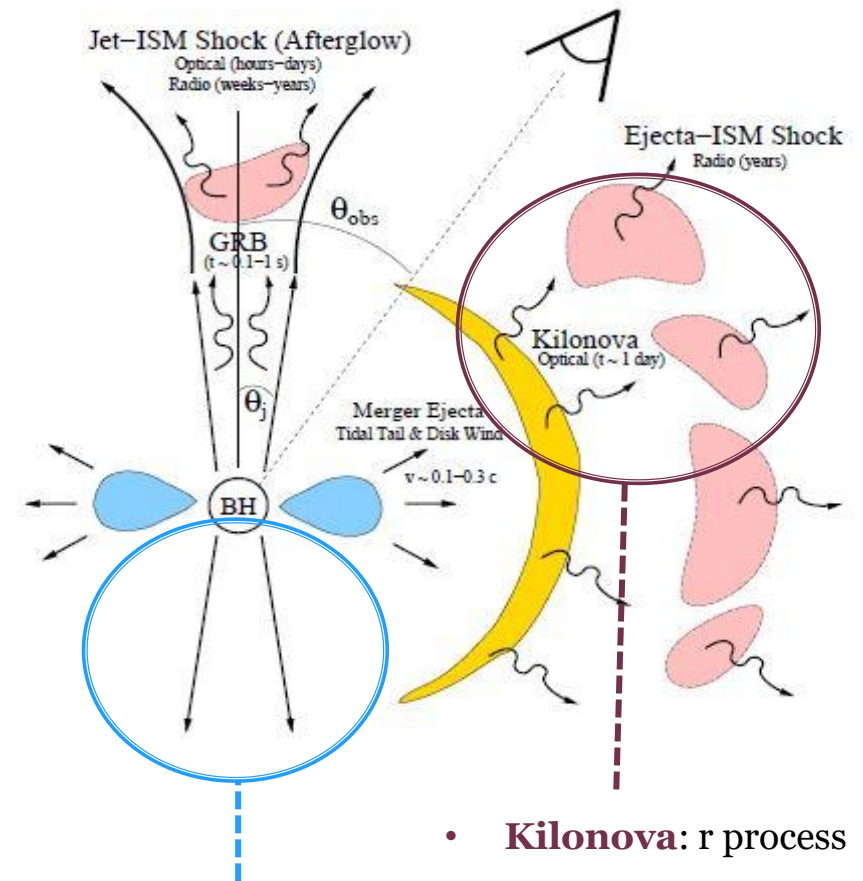

- **Kilonova:** r process
- **Gamma-Ray Burst:** Prompt and Afterglow emission

2) EM counterpart: Different emissions

- Relativistic jet
- Dynamical ejecta
- Wind ejecta

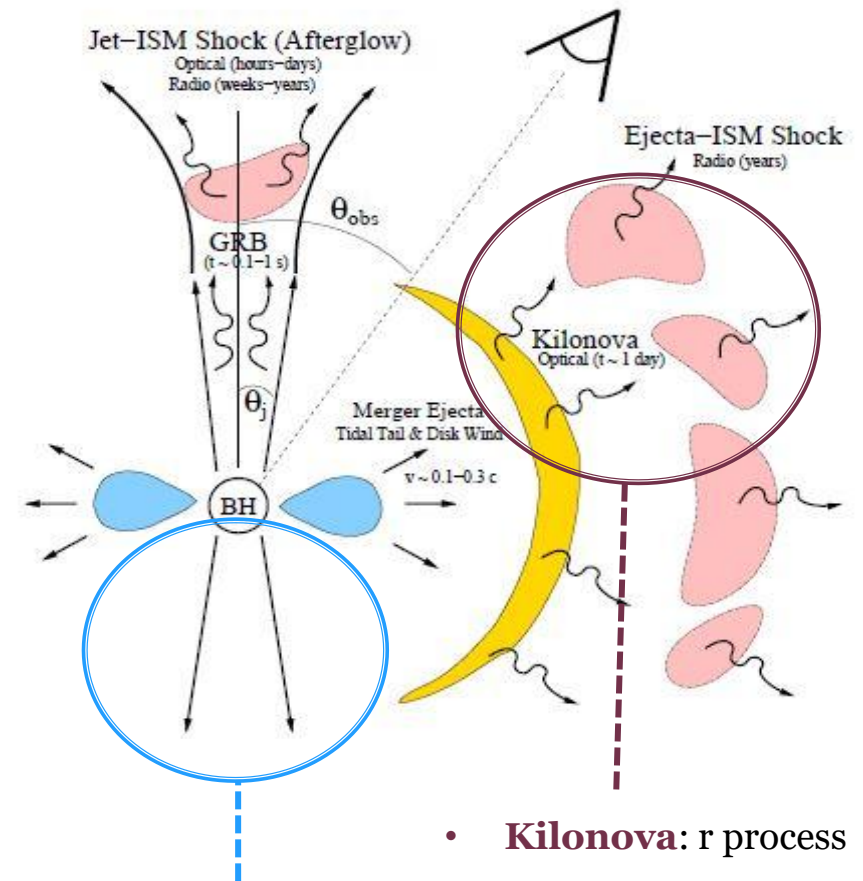
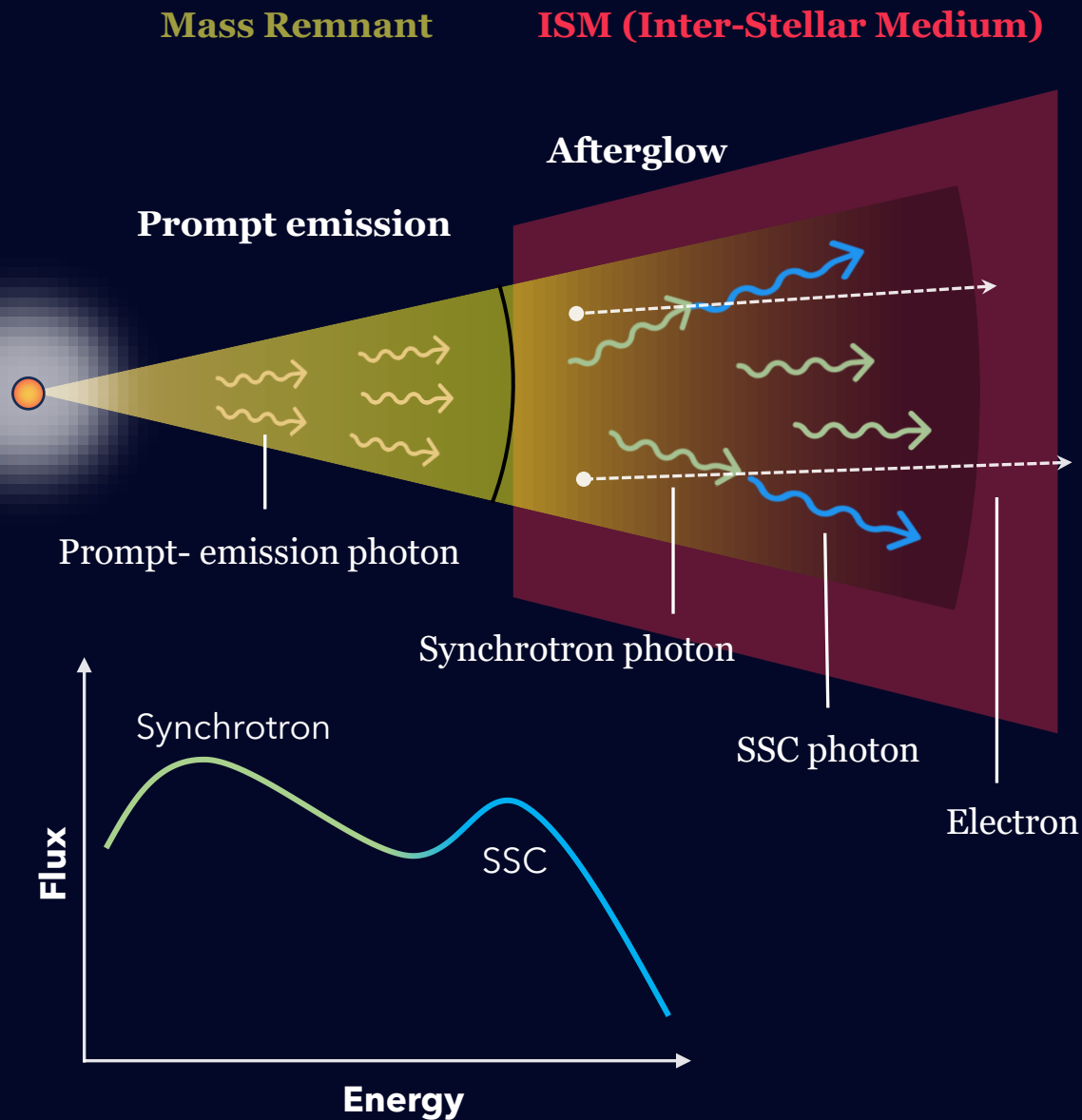

- **Gamma-Ray Burst:** Prompt and Afterglow emission

GW detectors

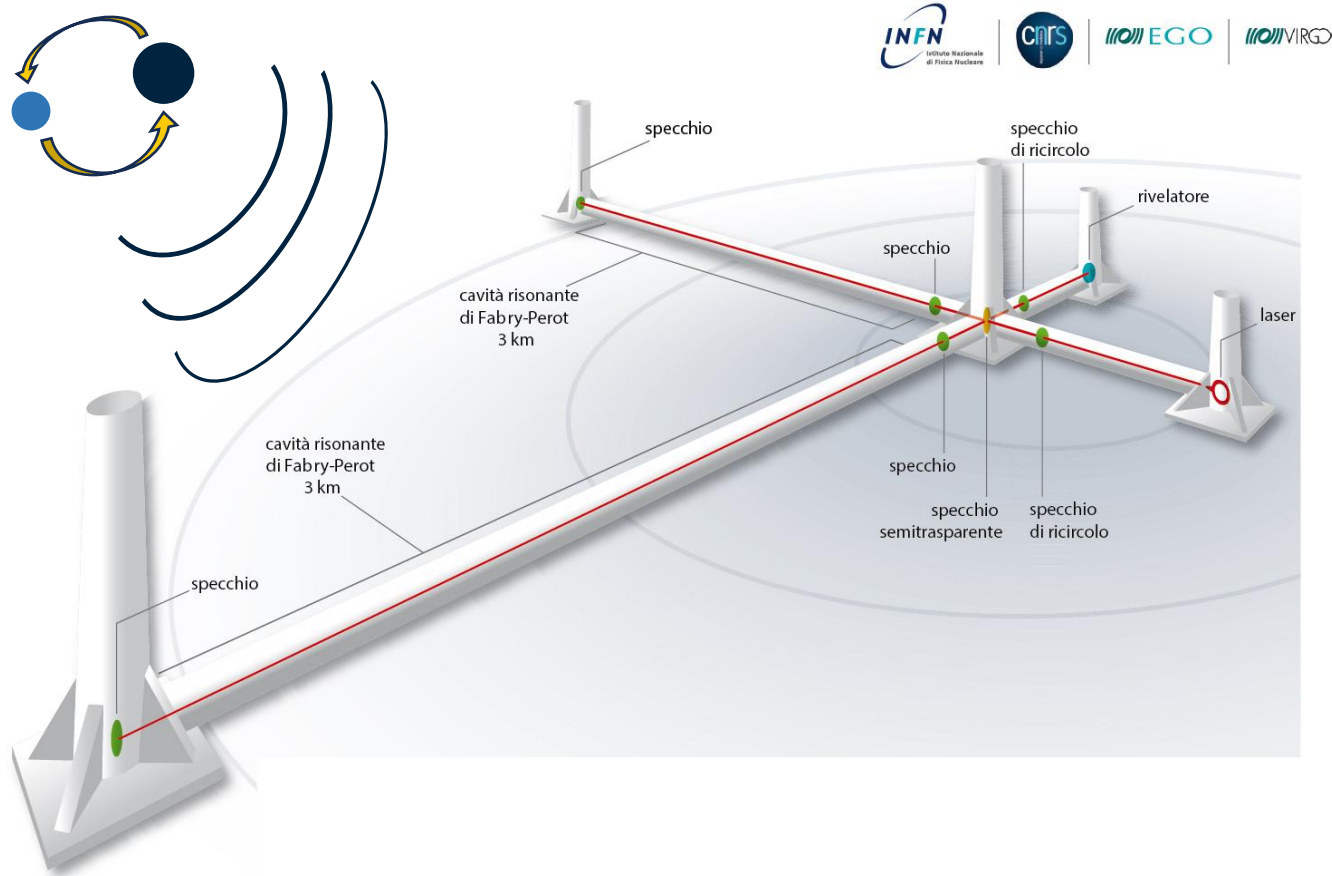

Schematic representation of the LIGO - VIRGO - KAGRA detectors

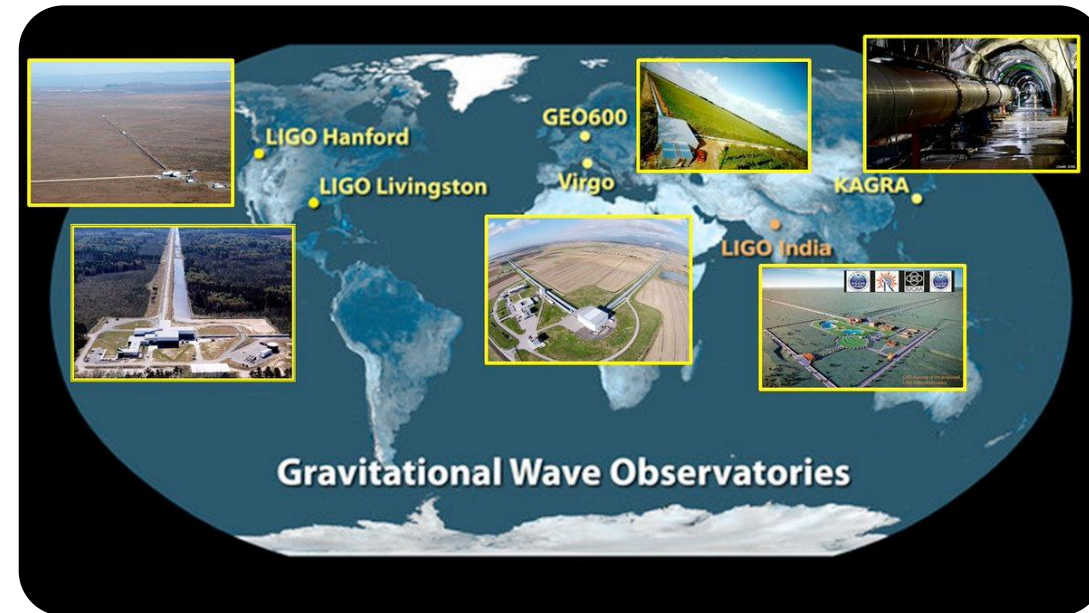

GW Interferometers LVK **community** around the world

GW detectors

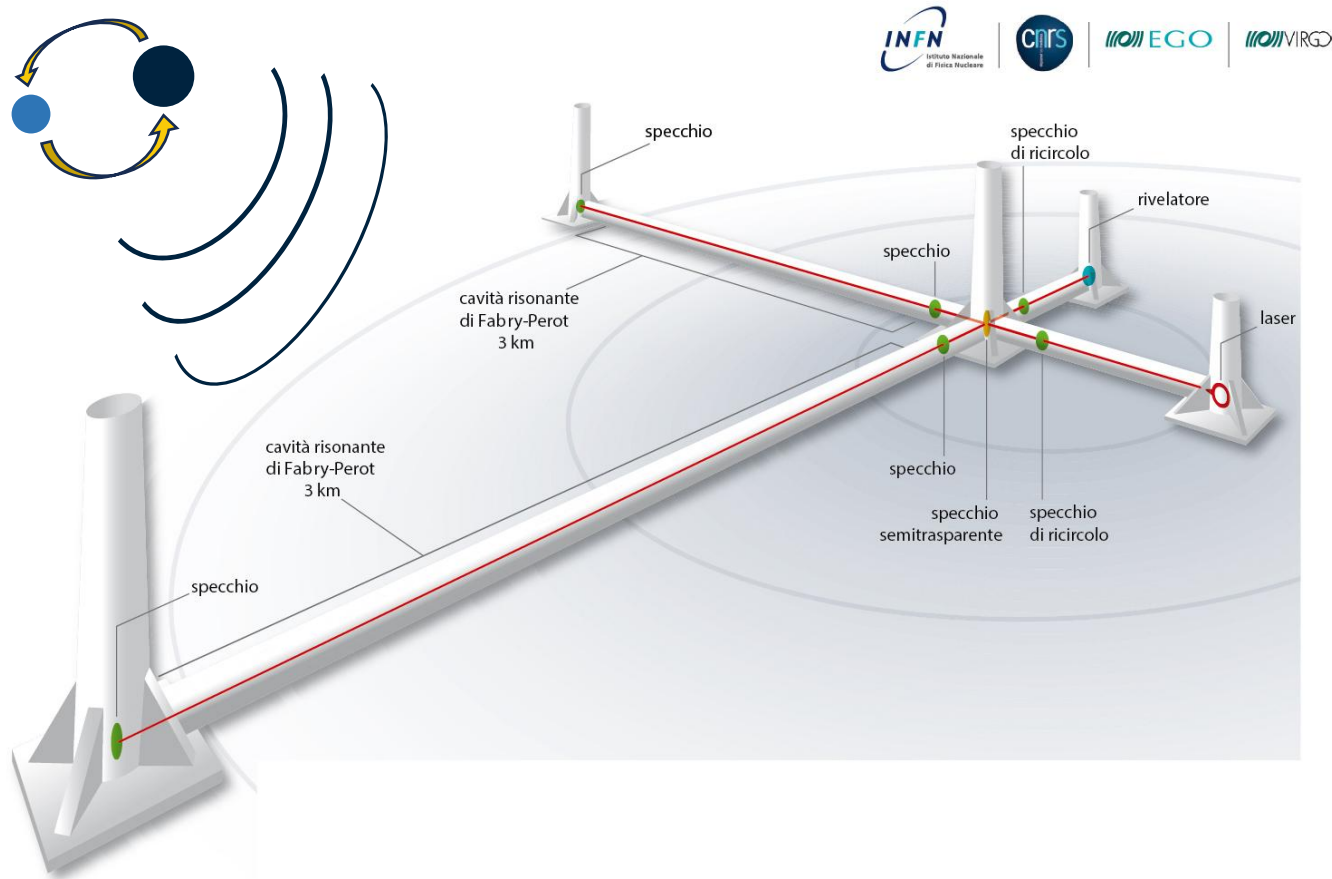

VIRGO (Cascina- Italy)

Schematic representation of the LIGO - VIRGO - KAGRA detectors

GW Future Detectors

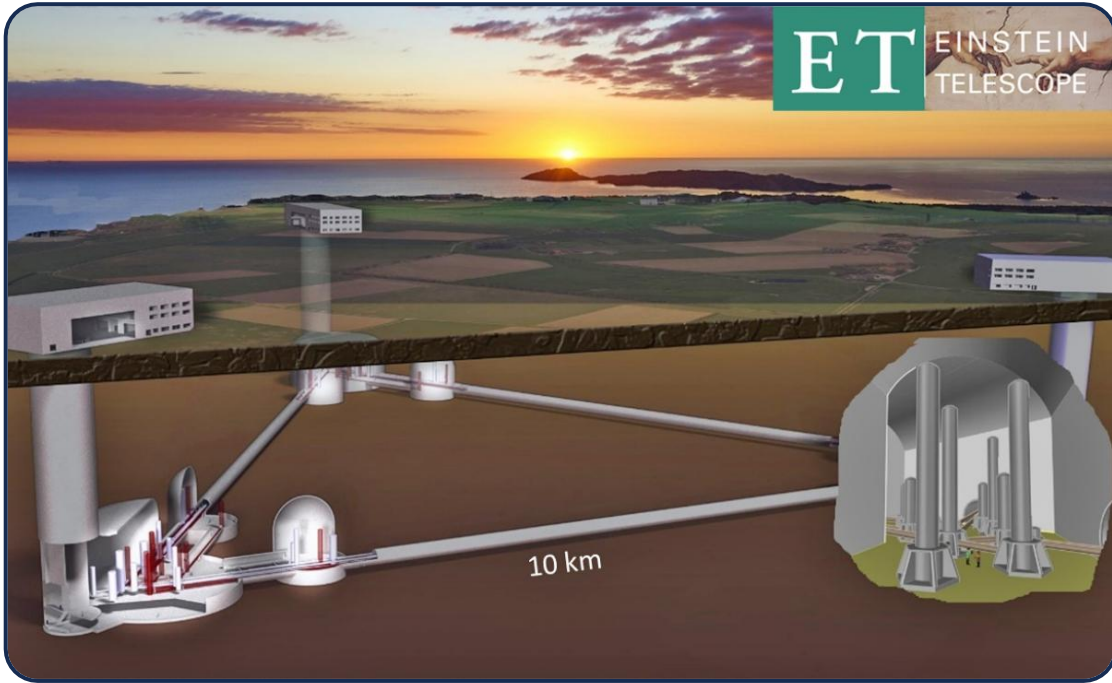

Schematic representation of the **Einstein Telescope (ET)** detector

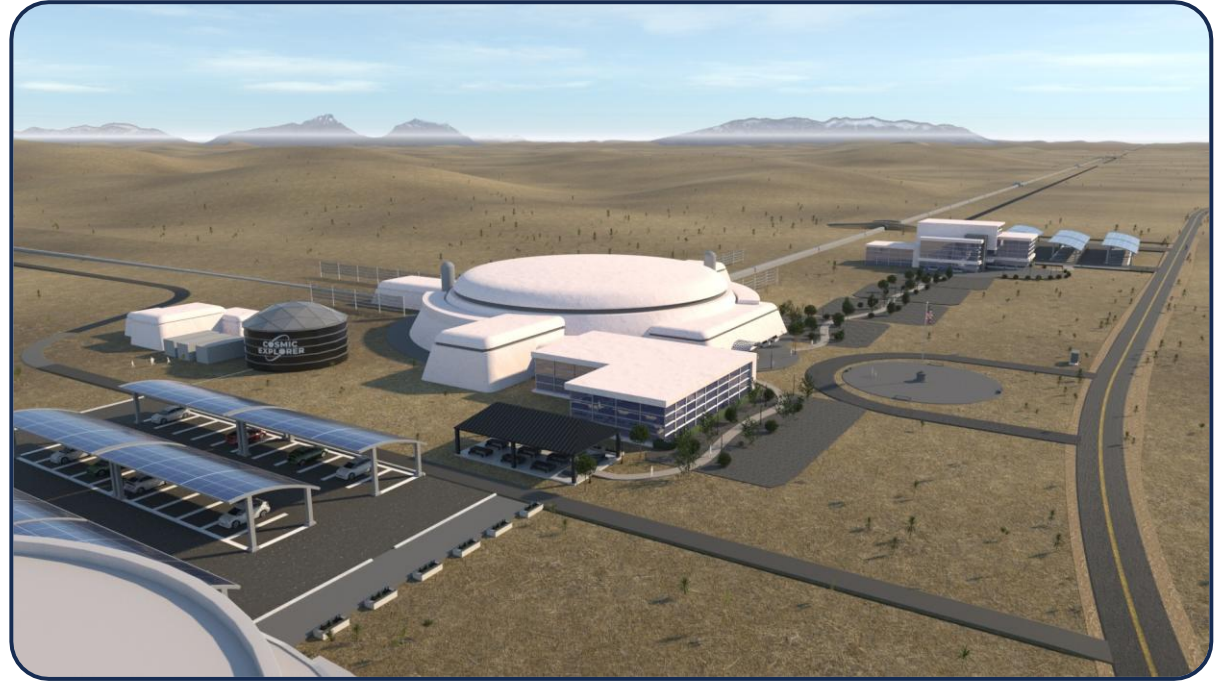

Schematic representation of the **Cosmic Explorer (CE)** detector

GW Future Detectors

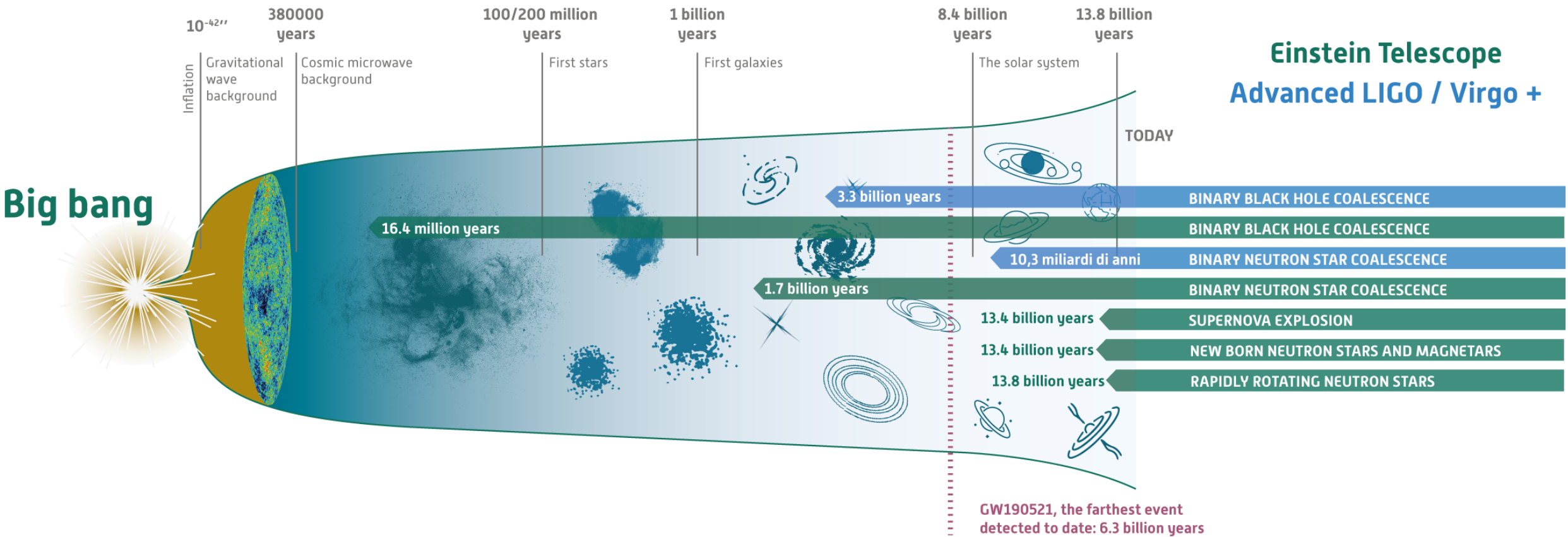

GW detections

Before O4 run

Masses in the Stellar Graveyard

LIGO-Virgo-KAGRA Black Holes LIGO-Virgo-KAGRA Neutron Stars

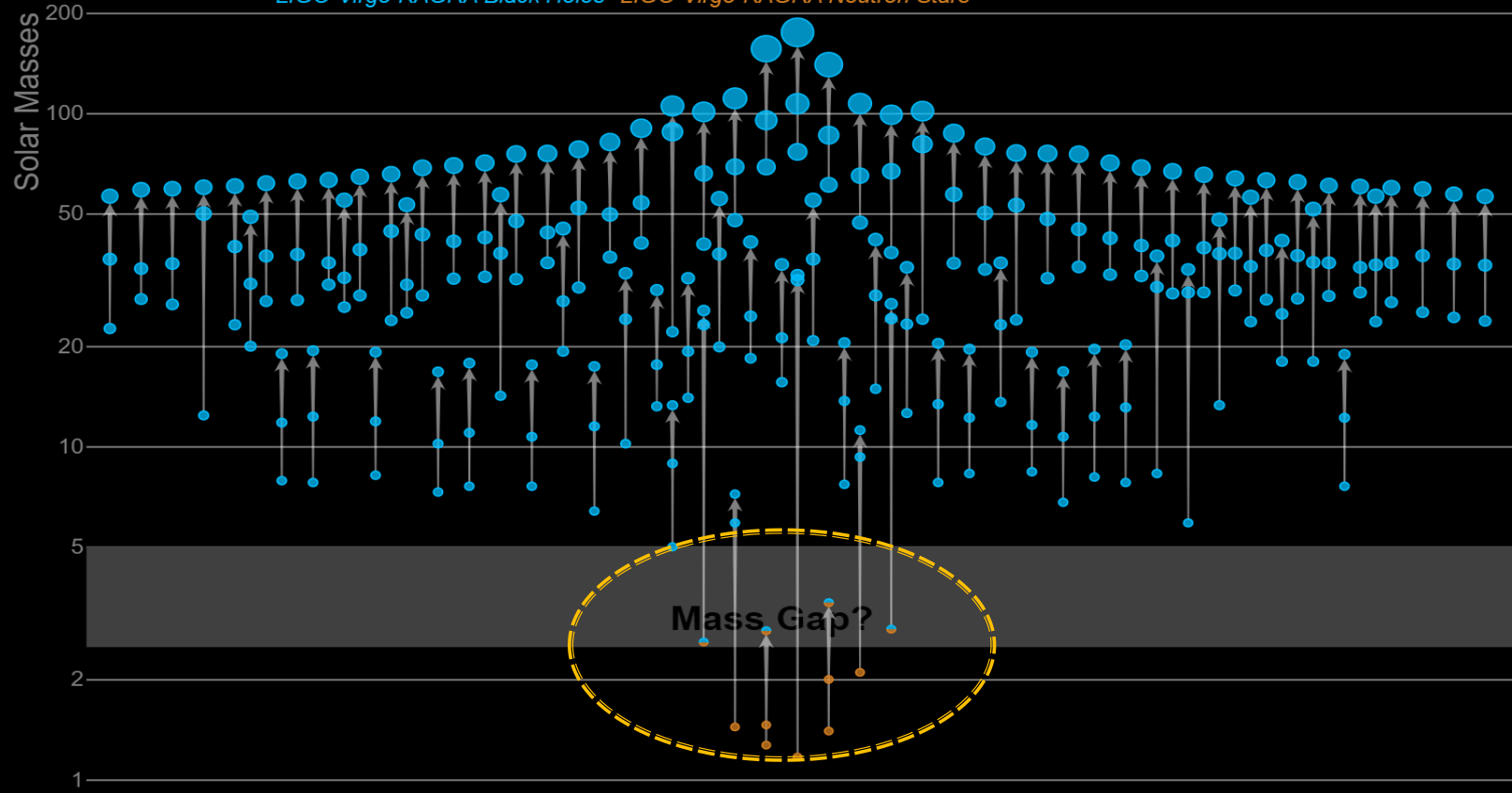

LIGO-Virgo-KAGRA | Aaron Geller | Northwestern

Simulations



Expected events in the **future**

Detector	NS-BH
AdLIGO	1.2 – 9.3
A+	3.2-26
ET + CE	2.4×10^3 - 2.2×10^4

In O4 obs. run
(May 2023 to Feb 2025)

- 196 Events
- ~ 186 BBH
- ~ 8-10 NSBH

- It catches the **Cherenkov light** from EM showers
- **Energy range:** 20 GeV- 300 TeV

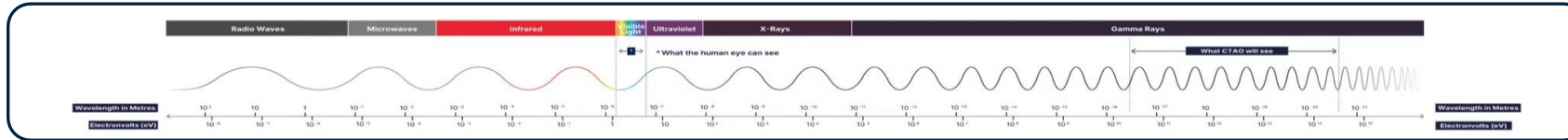

Cherenkov Telescopes Array Observatory



- It catches the **Cherenkov light** from EM showers
- **Energy range: 20 GeV- 300 TeV**

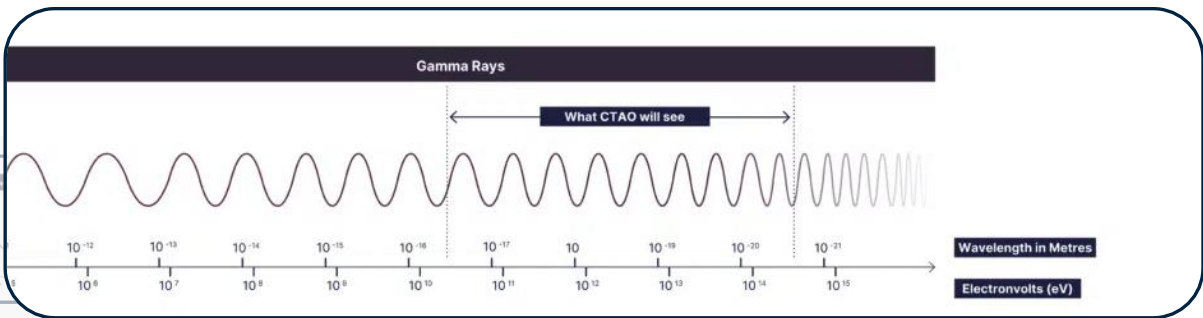
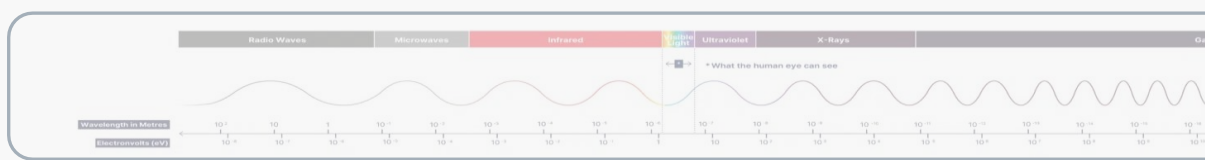

- More than **60** telescopes of different **sizes** in the north and south hemisphere:
 - **Large-Sized**, low-energy range (**20 to 150 GeV**).
 - **Medium-Sized**, core energy range (**150 GeV to 5 TeV**).
 - **Small-Sized** above **5 TeV**.

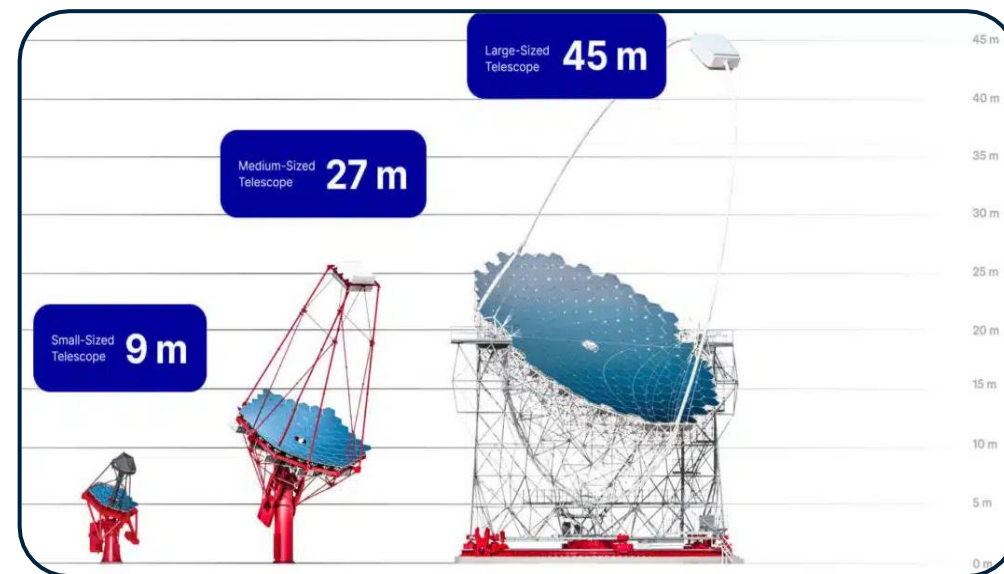
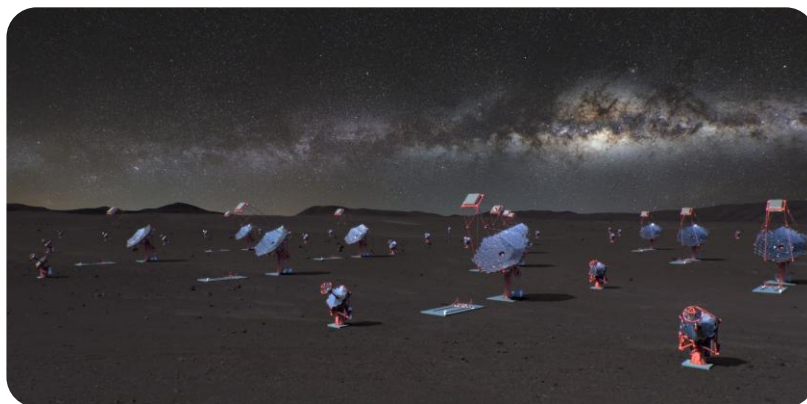

Synchrotron Self Compton model



Blandford & McKee solutions

R. Blandford & C. McKee (1976) – Self-Similar Solutions for Relativistic Blast Waves

- Ultra-relativistic spherical blast wave enclosed by a strong shock
- Fixed amount of Energy in a uniform medium

Sedov-Taylor solution in relativistic regime: $\Gamma \gg 1$ (We consider $\Gamma > 5$ in this work)

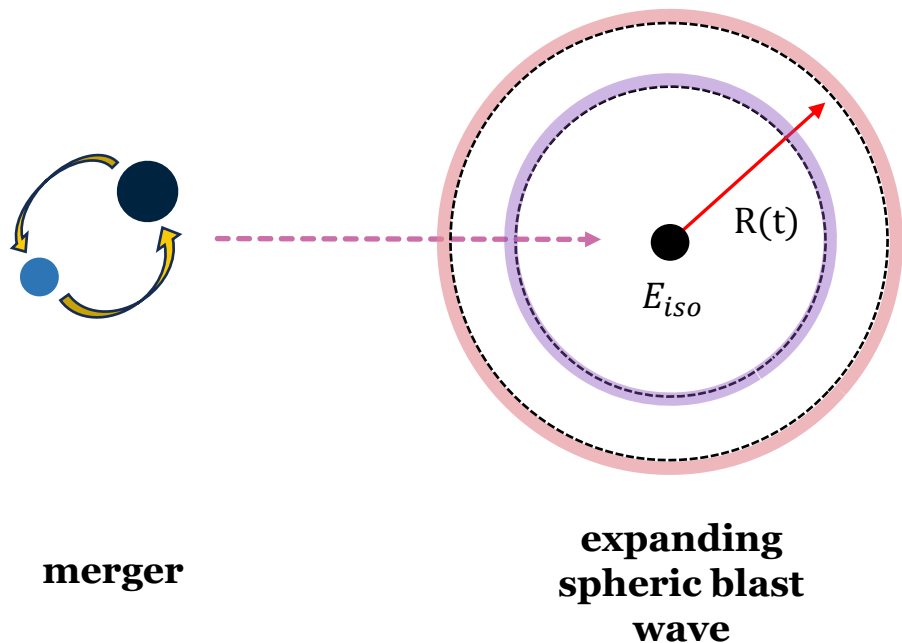

$$\Gamma^2 = \frac{E_{iso}}{Mc^2} \quad M(R) = \frac{4\pi R^3 n m_p}{3}$$

$M = \text{mass of the explosion products}$

$$\Gamma = \left(\frac{17E_{iso}}{16\pi n m_p R^3 c^2} \right)^{1/2}$$

From Sphere to expanding cone

Opening angle θ_c \downarrow $\theta_{\text{viewing}} \sim 1/\Gamma$

No lateral expansion until

$$\Gamma \gg 1/\theta_c$$

We can consider every portion of the jet is like a mini spheric blast wave

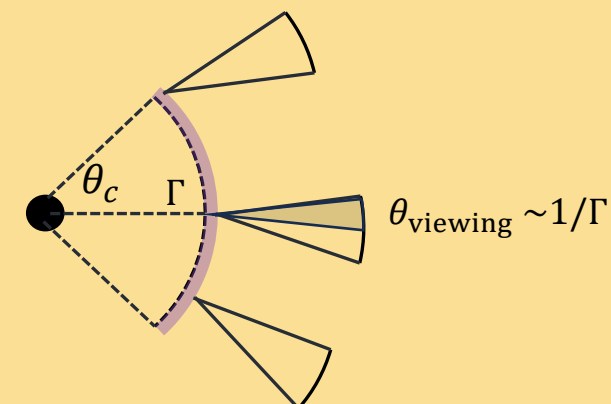

Structured jet model: θ dependence

Structured jet model $E_{isotropic} = E(\theta)$

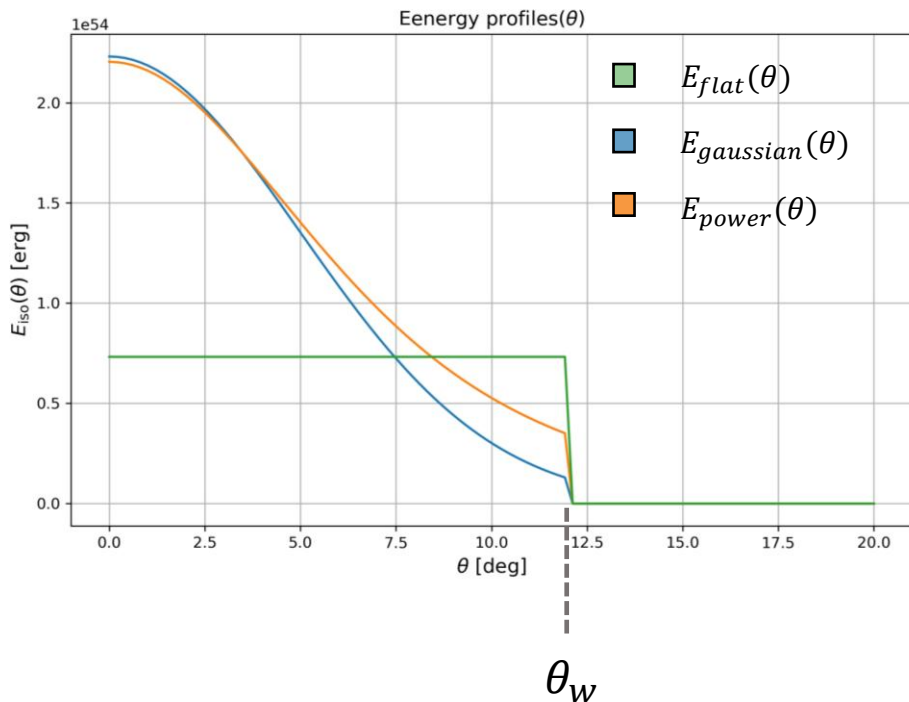

Top hat model

$$E_{flat} \begin{cases} E_{iso,0}, & \theta \leq \theta_w \\ 0, & \theta > \theta_w \end{cases}$$



Gaussian model

$$E(\theta) \begin{cases} E_{iso,0} \exp\left(-\frac{\theta^2}{2\theta_c^2}\right), & \theta \leq \theta_w \\ 0, & \theta > \theta_w \end{cases}$$

Power law model

$$E(\theta) \begin{cases} E_{iso,0} \left(1 + \frac{\theta^2}{b\theta_c^2}\right), & \theta \leq \theta_w \\ 0, & \theta > \theta_w \end{cases}$$

Ryan et al. 2020

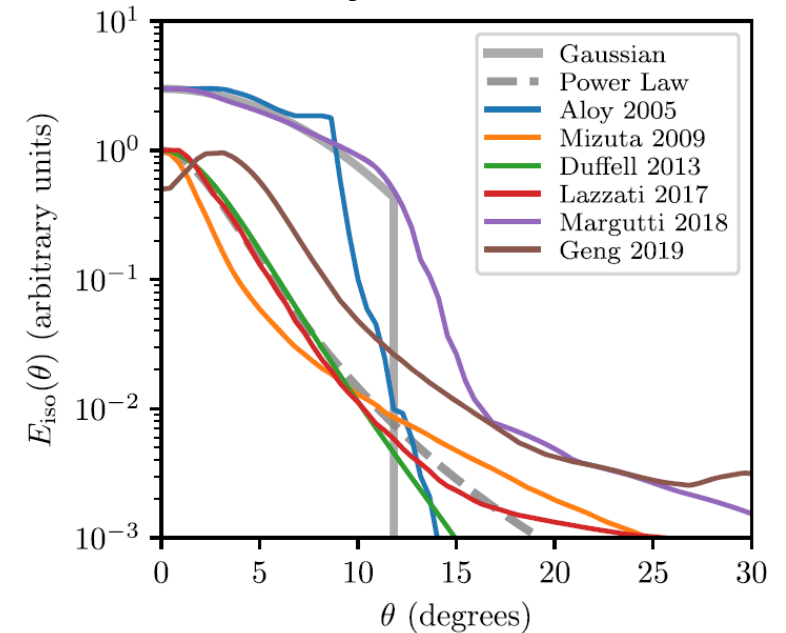

Structured jet model: θ dependence

In the second step we build a structured jet model: **expanding shells (θ)** • $E_{isotropic} = E(\theta)$

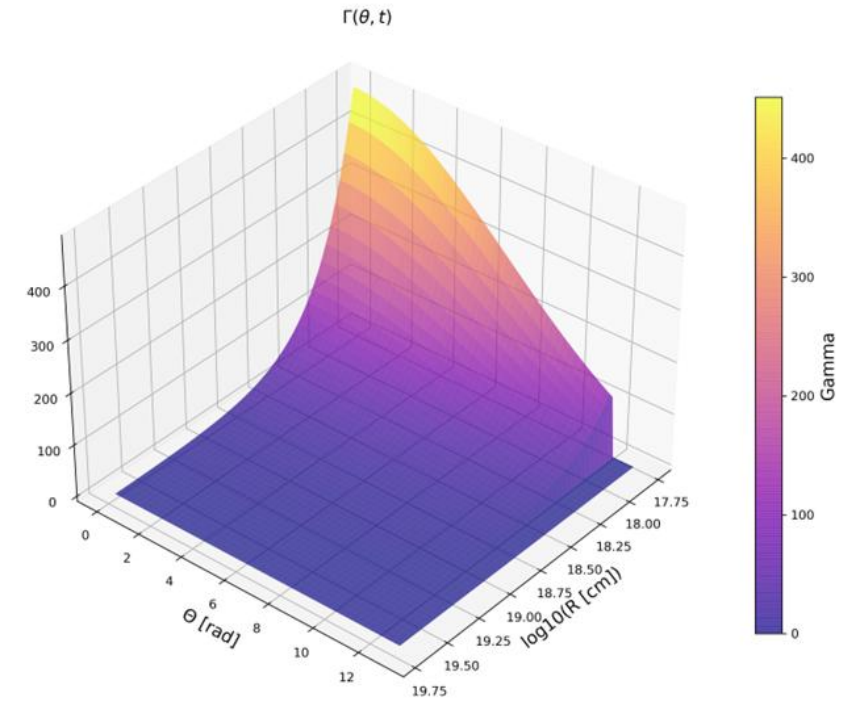
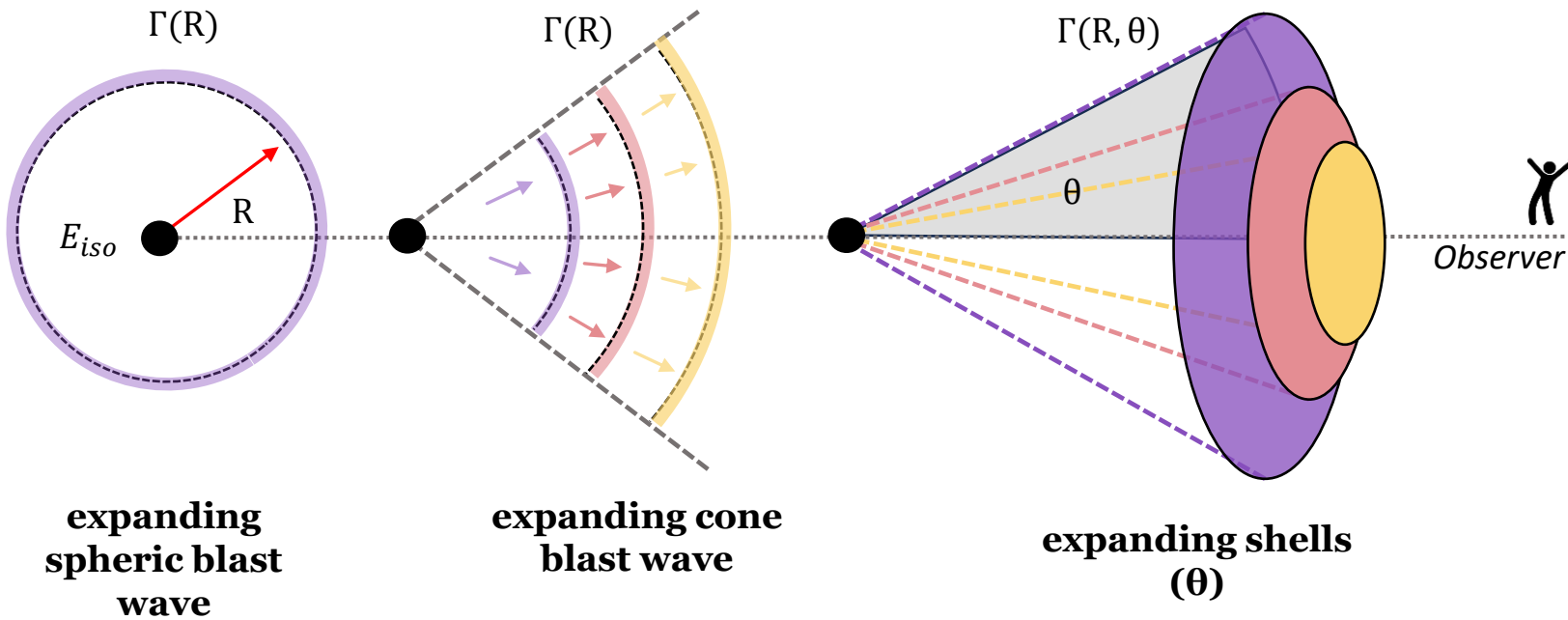

$$\Gamma = \left(\frac{17E_{iso}(\theta)}{16\pi n m_p R^3 c^2} \right)^{1/2}$$

Arrival times: On Axis

t_{lab}

t_{obs}

Different arrival times

$$t_{obs} = (1+z) \left[t_{lab}(R) - \frac{R \cos \theta}{c} \right]$$

$$t_{obs} = (1+z) \left[\int_0^R \frac{dR'}{2c\Gamma^2(R')} \right] + \frac{R\theta^2}{2c}$$

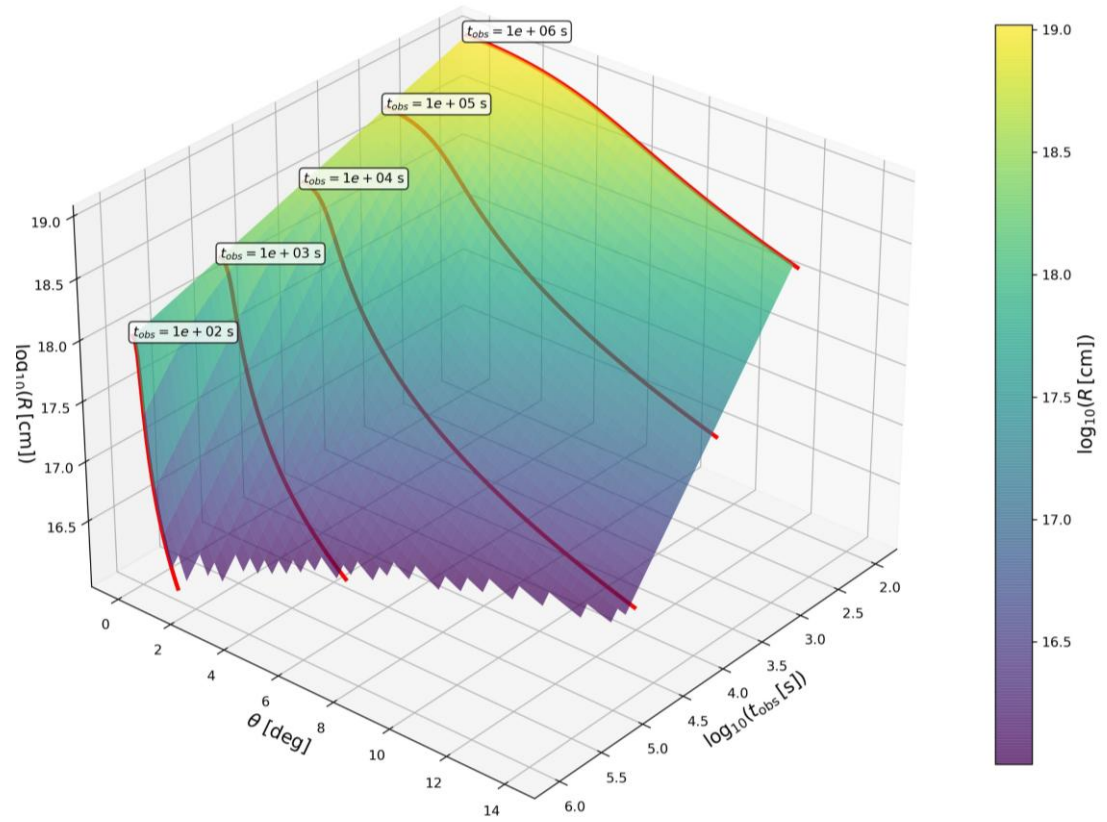

Solution Condition

$$t_{obs}(R, \theta) = \text{constant}$$

Equal Arrival Time Surface

$$R(\theta, t_{obs})$$

Arrival times: Off Axis

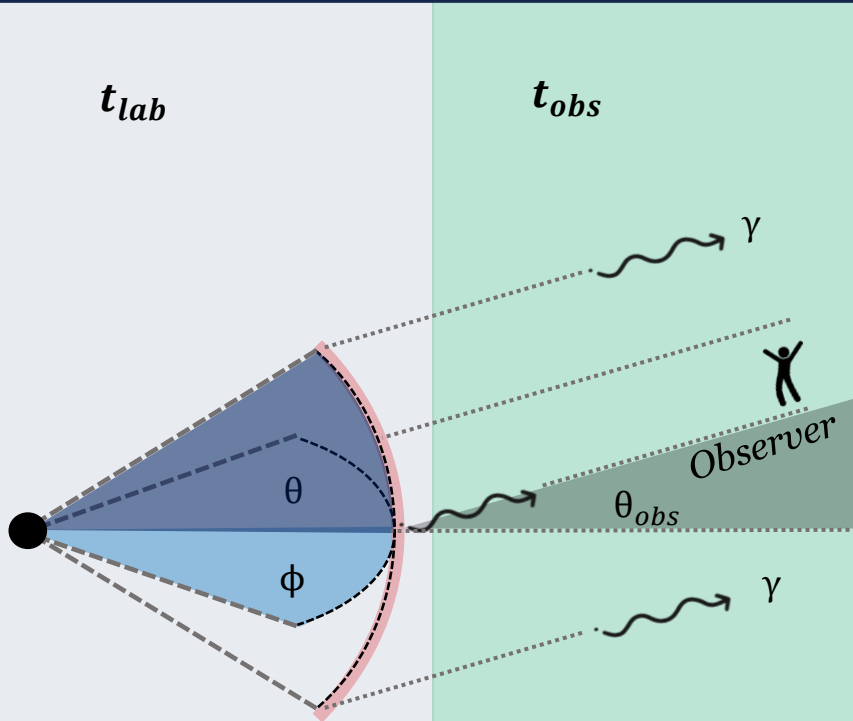

$$t_{obs} = (1+z) \left[t_{lab}(R) - \frac{R(t)\mu(\theta, \phi)}{c} \right]$$

$$\mu(\theta, \phi, \theta_{obs}) = \cos\theta \cos\theta_{obs} + \sin\theta \sin\theta_{obs} \cos\phi$$

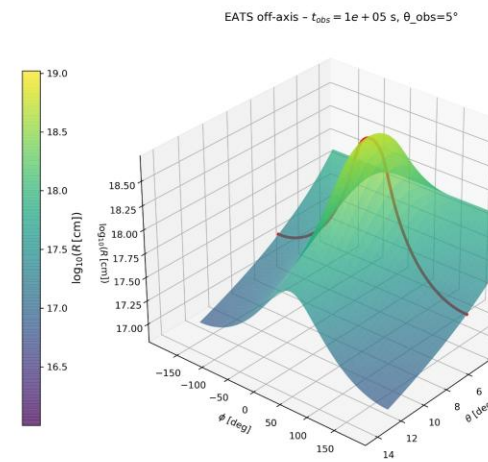
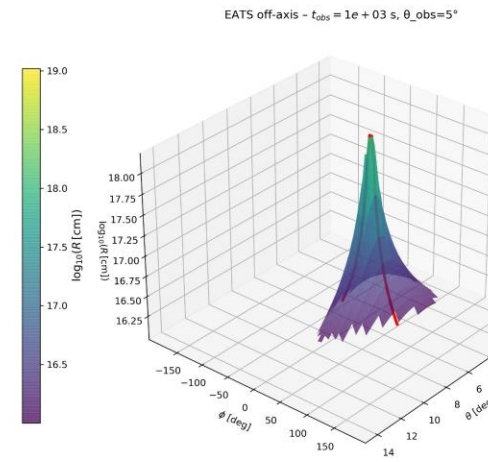
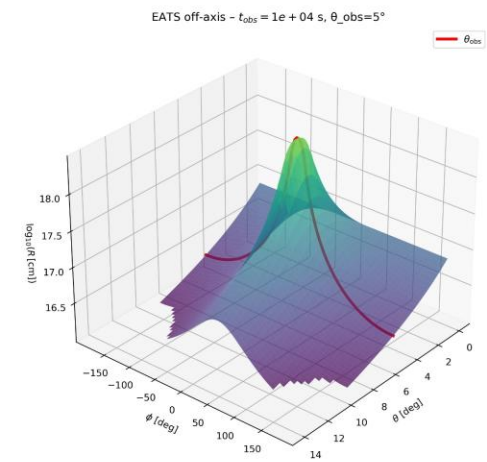
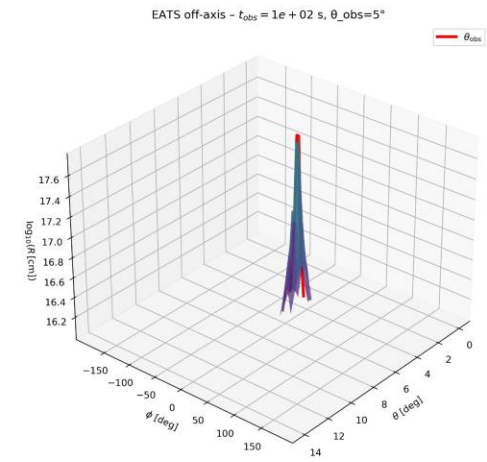

Solution Condition

$$t_{obs}(R, \theta, \phi, \theta_{obs}) = \text{constant}$$

Equal Arrival Time Surface

$$R(\theta, \phi, \theta_{obs}, t_{obs})$$



Valid EATS

Not every R of the *EATS* is valid: R must be $>$ deceleration Radius (R_{dec})

$$R_{dec} = \left(\frac{3E}{4\pi n m_p c^2 \Gamma_0^2} \right)^{1/3}$$

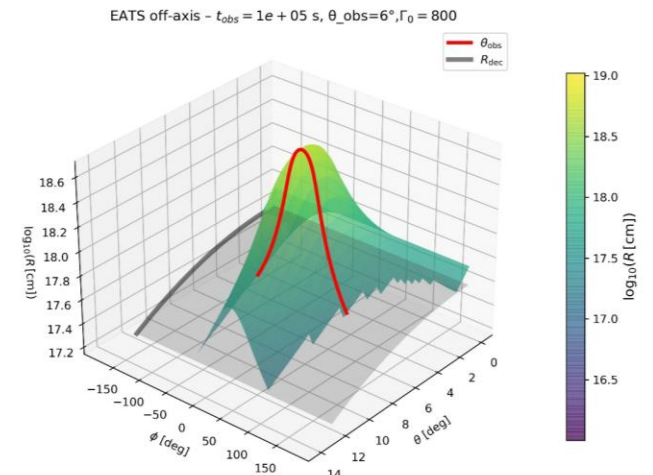
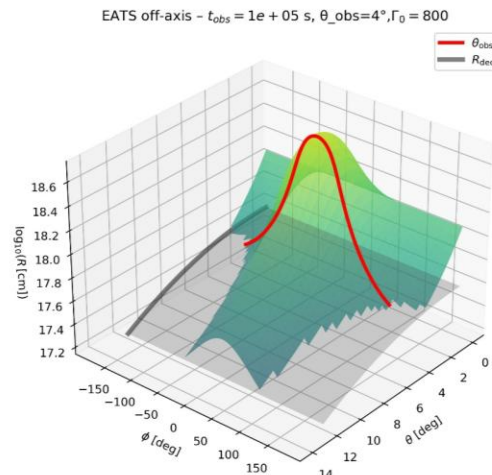
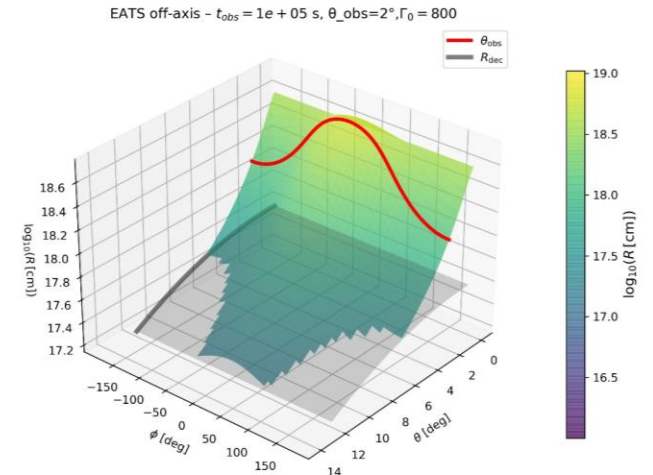
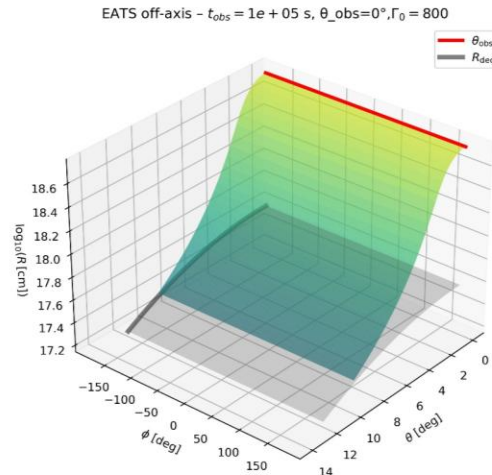
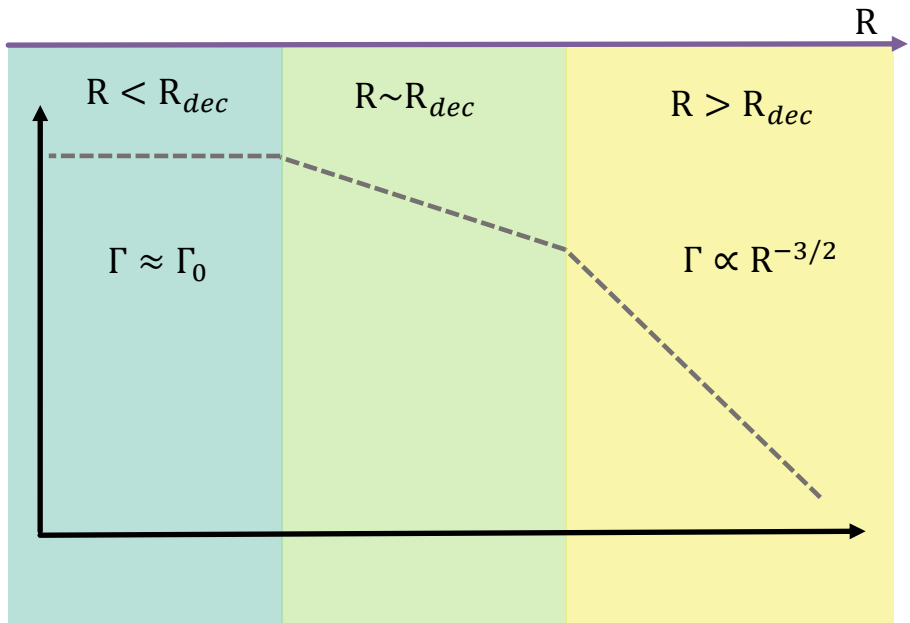

Building the grid

We want to build up a proper grid for the angles: Shells number ($N_\theta = N_\phi$)

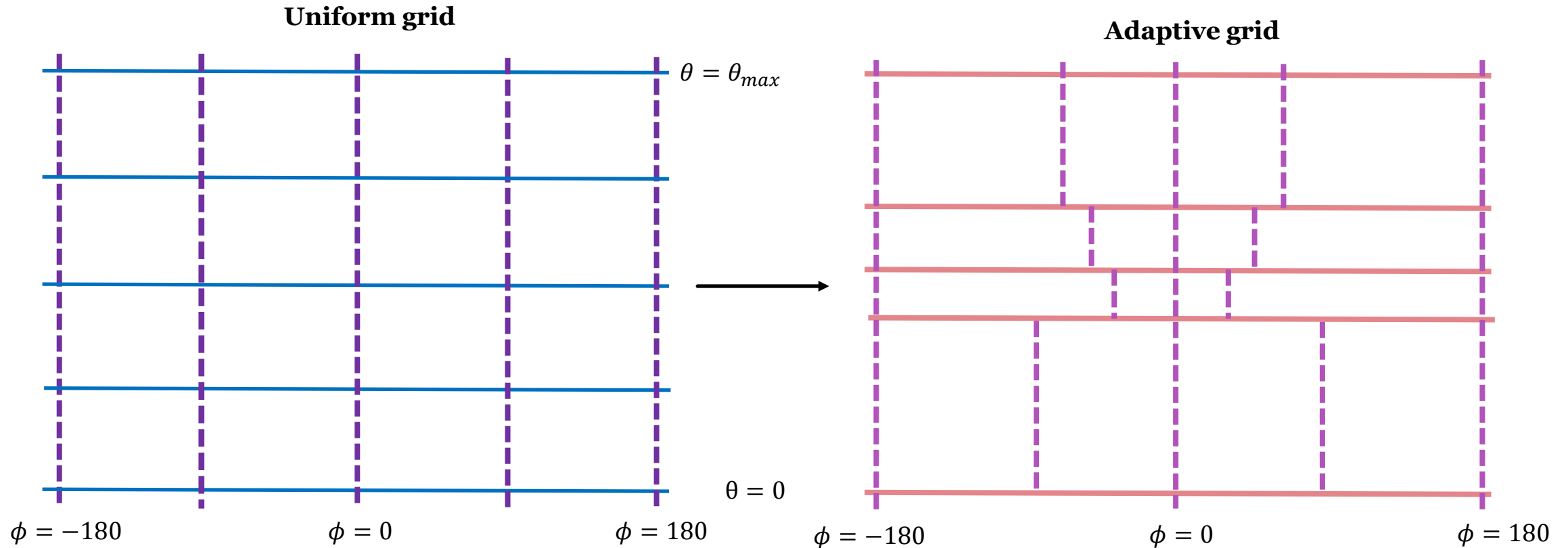

Doppler beaming

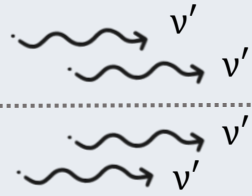

Relativistic beaming

$$\delta(\theta) = \frac{1}{\Gamma(1 - \beta \cos\theta)}$$

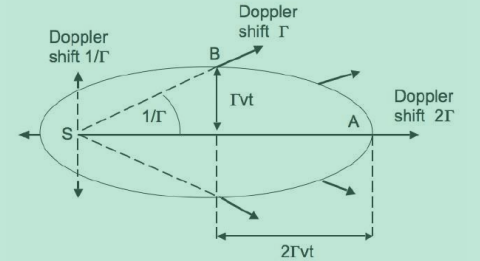
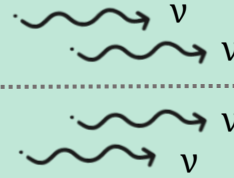

P. Mészáros 2006 «Gamma-Ray Bursts»

$\delta(\theta, \phi)$ on EATS

$$v = \delta v' \quad d\Omega = \delta^{-2} d\Omega' \quad dV = \delta dV' \quad j_v(v) = \delta^2 j_{v'}(v')$$

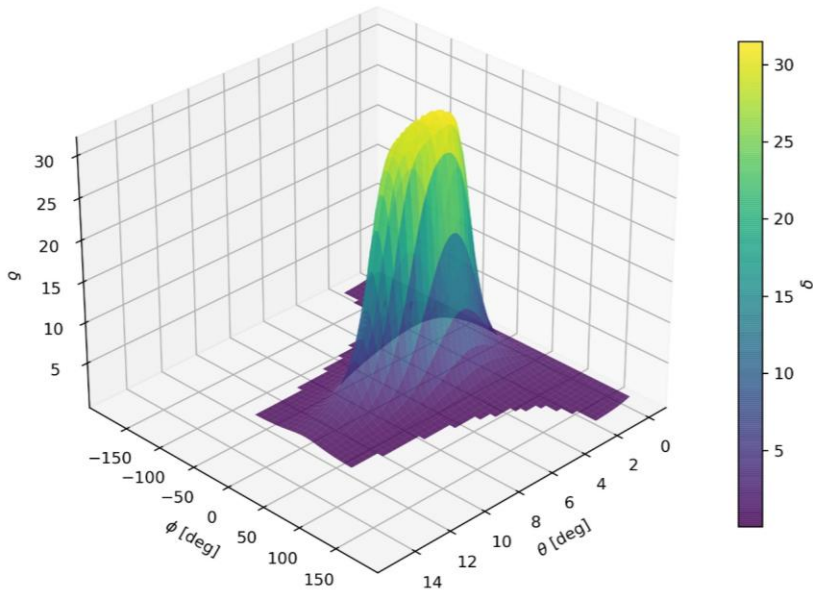

The grid matters!

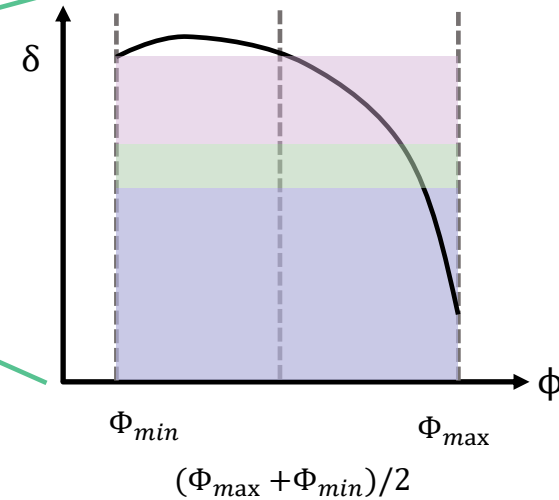
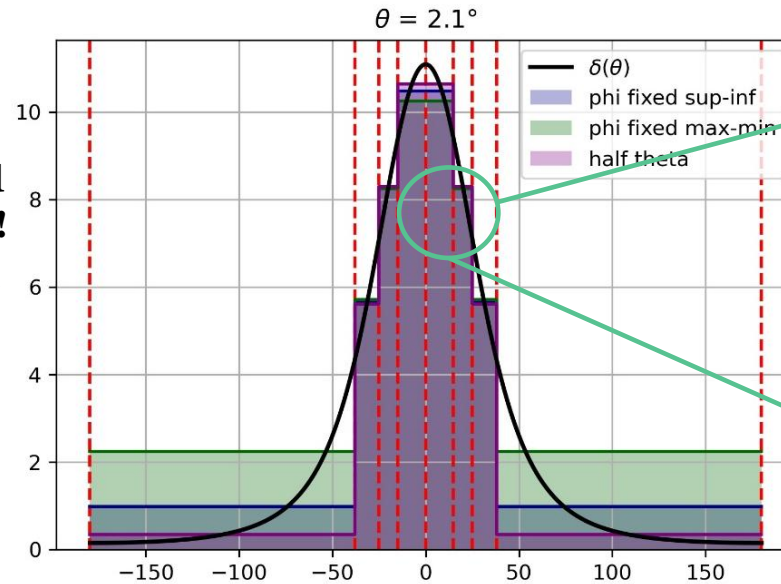

$$\delta(\theta, \phi, \theta_{obs}) = \frac{1}{\Gamma(1 - \beta \mu(\theta, \phi, \theta_{obs}))}$$

Synchrotron Self Compton emission

$$\frac{dN_\gamma}{dE_\gamma dt} = \frac{\sqrt{3}}{2\pi} \frac{e^3 B}{m_e \hbar E_\gamma} F\left(\frac{E_\gamma}{E_c}\right) + N_e(\gamma) \quad \text{Electronic distribution (Broken power law)}$$



$$\epsilon'_{\nu'} \equiv \frac{dN_\gamma}{dE dt} = \int N_e(\gamma) \frac{dN_\gamma}{dE_\gamma dt} d\gamma$$

Emissivity function



Synchrotron photon density



Inverse Compton field

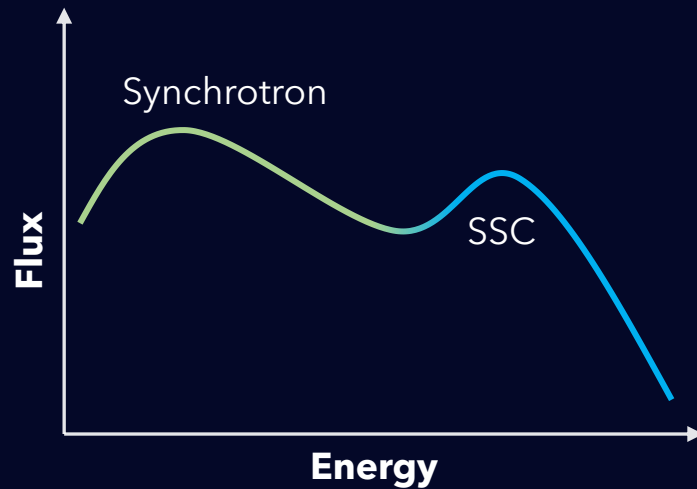

Flux computation

$$F_\nu(t_{obs}, \nu_{obs}) = \frac{1+z}{4\pi d_L^2} \int d\Omega R^2 \Delta R \delta^2 \epsilon'_{\nu'}$$

Ryan et al. 2020

$z = \text{redshift}$

$d_L = \text{distance luminosity}$



Computation on the grid

$$F_\nu(t_{obs}, \nu_{obs}) = \frac{1+z}{4\pi d_L^2} \sum_{i=1}^{N\theta} \sum_{j=1}^{N\phi} \Delta\theta \Delta\phi \sin\theta_{ij} R_{ij}^2 \Delta R_{ij} \delta_{ij}^2 \epsilon'_{\nu'}$$

$$\nu_{obs} = \frac{\delta}{1+z} \nu'$$

$$t_{obs} = (1+z) \left[t_{lab}(R) - \frac{R\mu(\theta, \phi)}{c} \right]$$

Main functions on grid (θ, ϕ) : On Axis

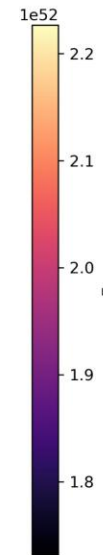
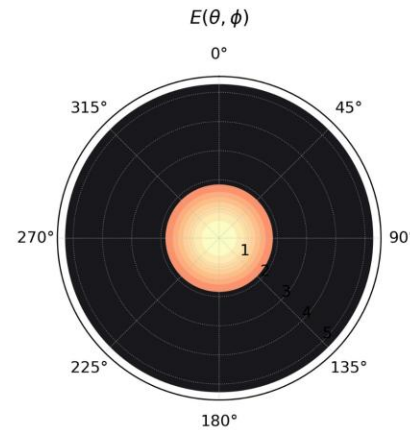
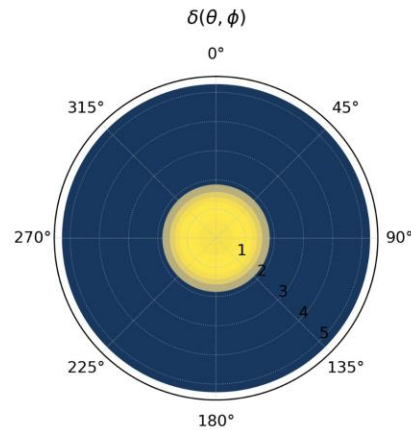
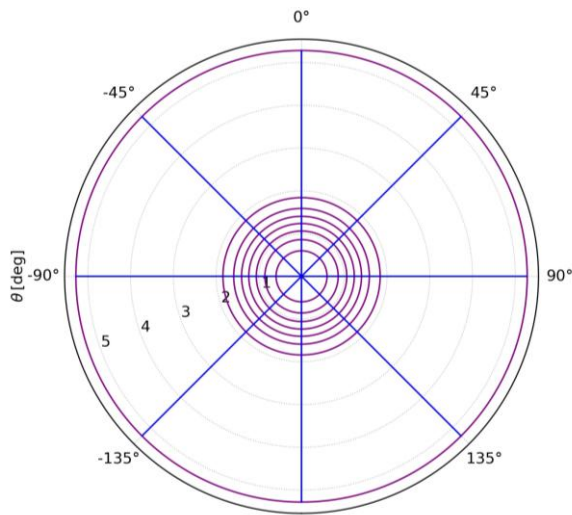
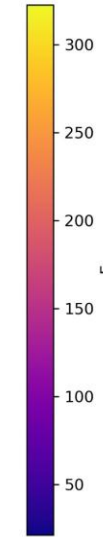
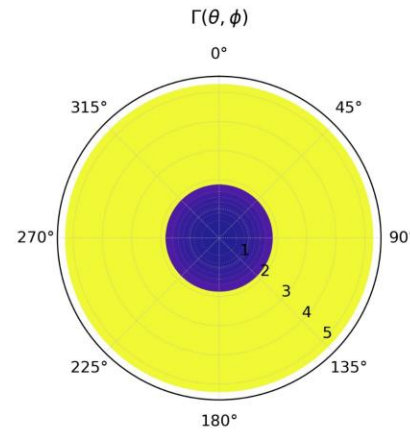
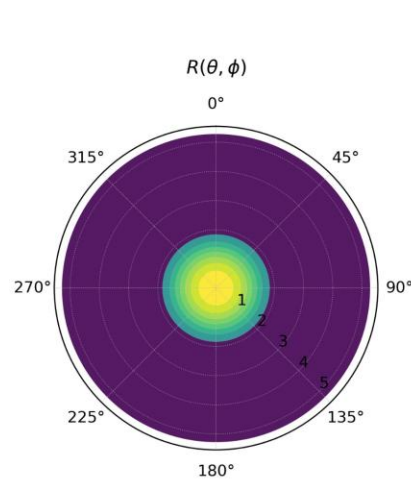
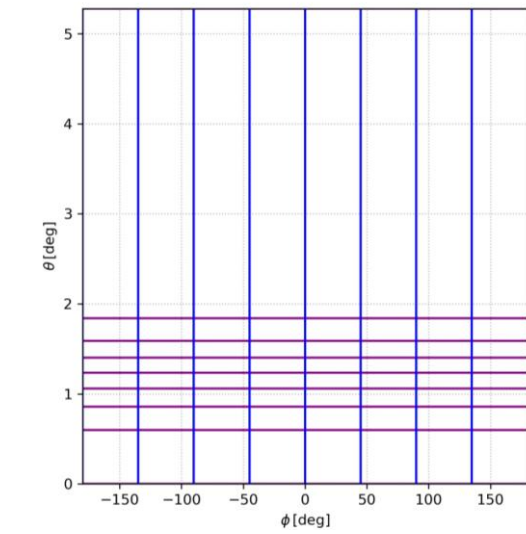

E_k	10^{51} erg
z	0.01
n_0	0.01 cm^{-3}
B	0.25 gauss



Main functions on grid (θ, ϕ) : Off Axis

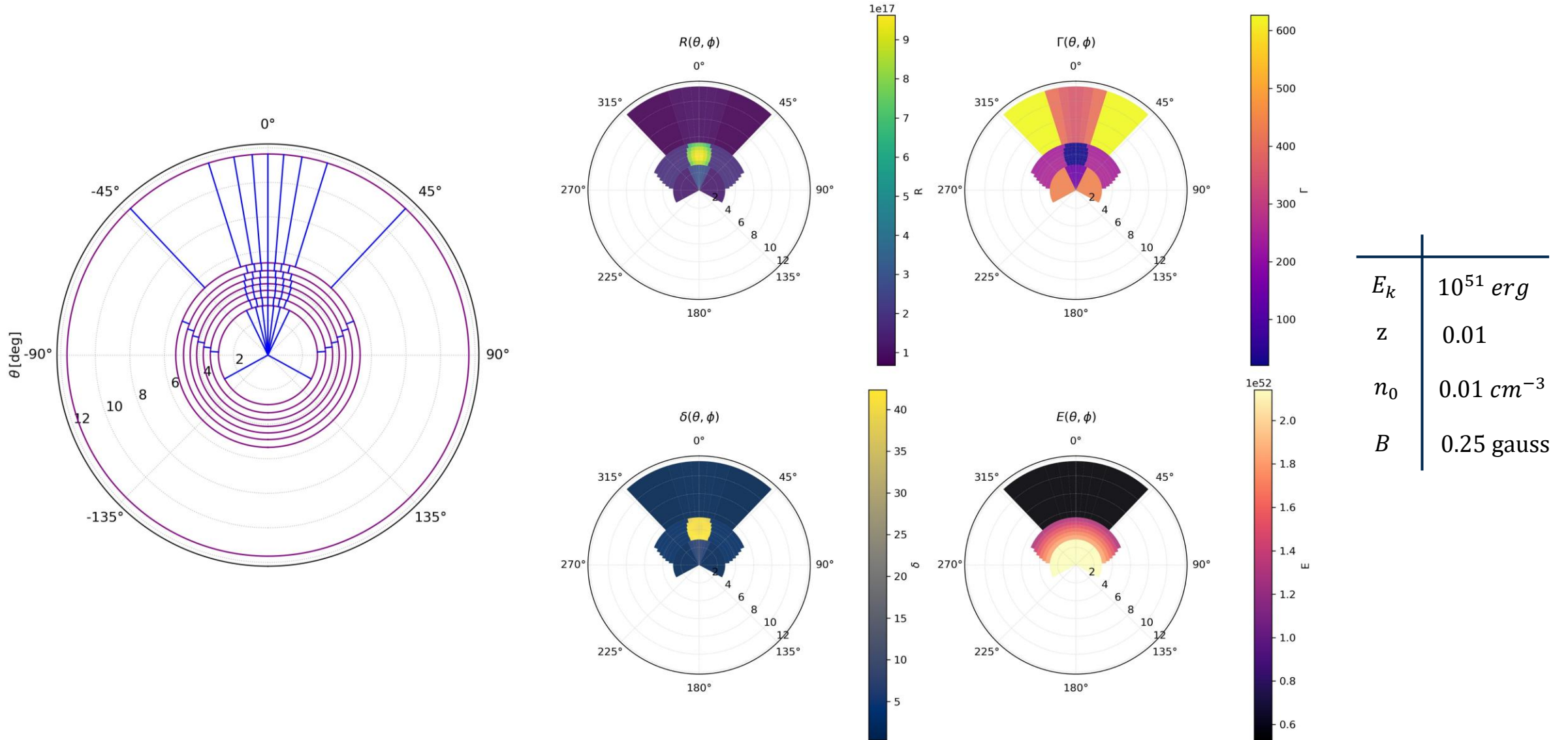

Spectral Energy Density ($t_{obs} = \text{fixed}$)

$$t_{obs} = 10^4 \text{ s } \theta_{obs} = 0^\circ$$

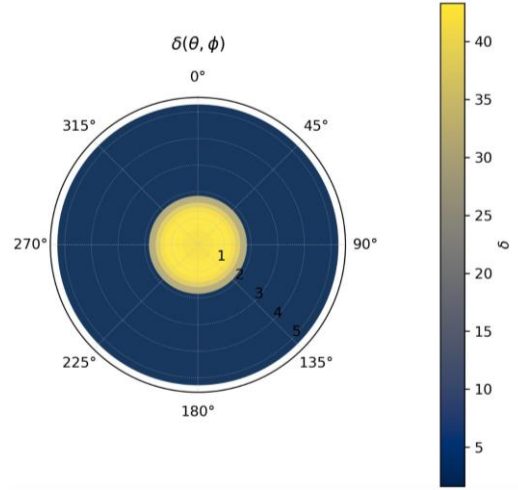

$$t_{obs} = 10^4 \text{ s } \theta_{obs} = 4^\circ$$

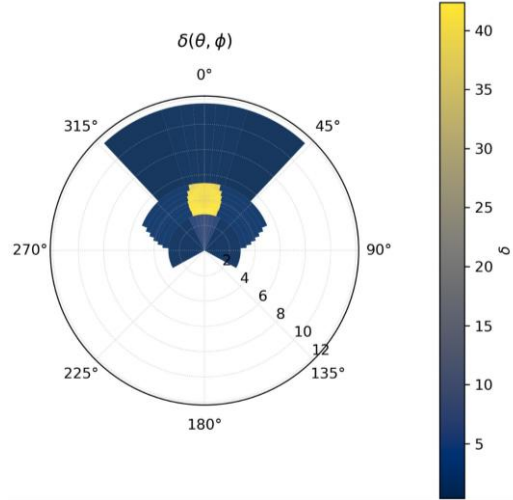

$$t_{obs} = 10^4 \text{ s } \theta_{obs} = 8^\circ$$

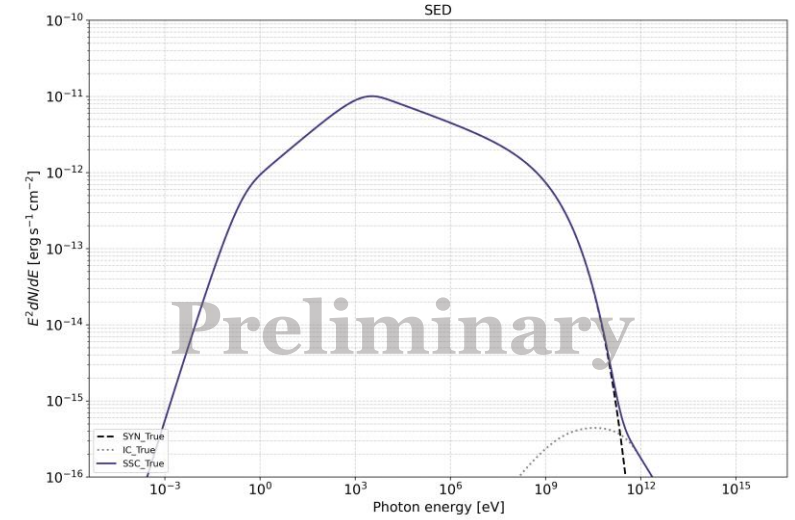
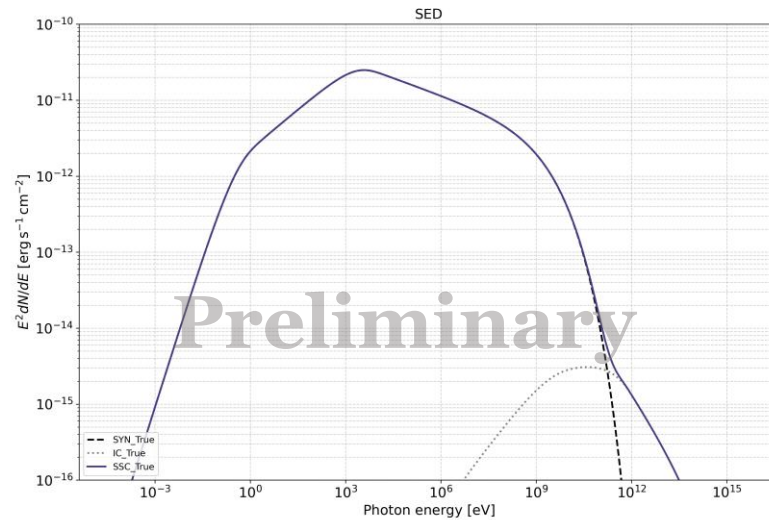
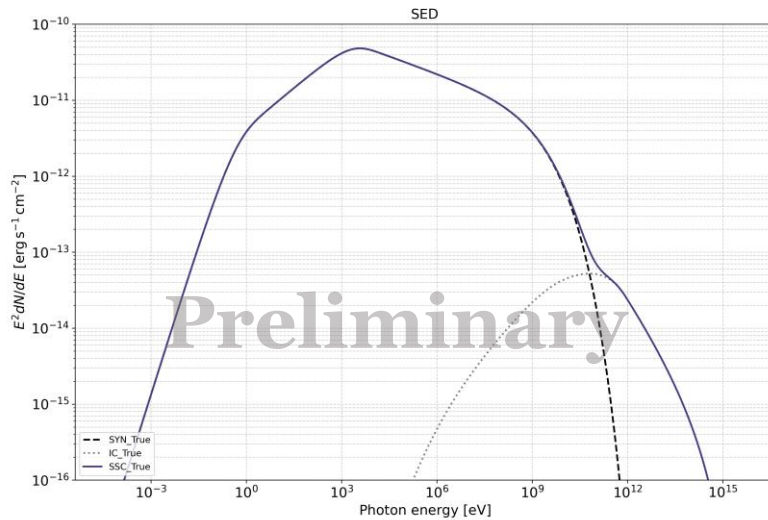
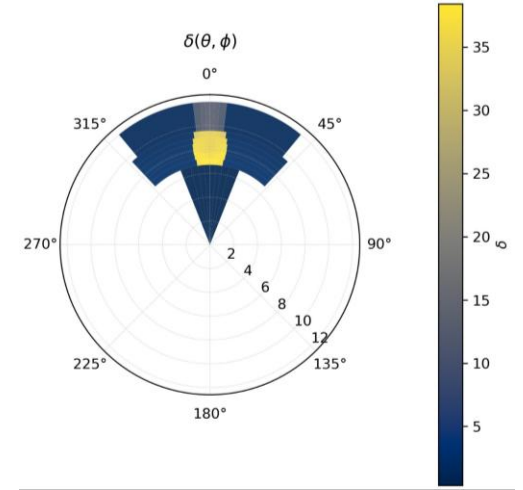

Spectral Energy Density ($t_{obs} = \text{fixed}$)

$$t_{obs} = 10^5 \text{ s } \theta_{obs} = 0^\circ$$

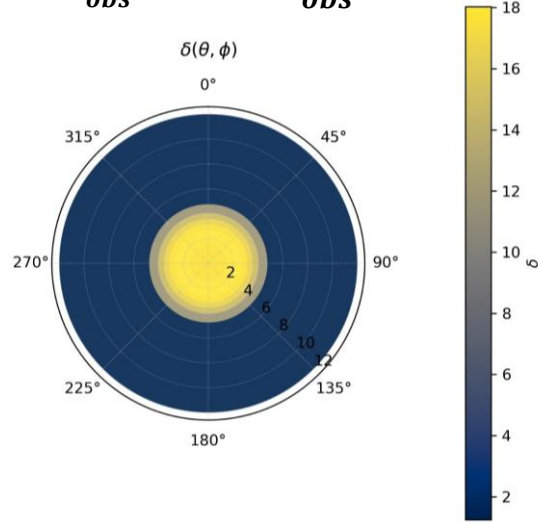

$$t_{obs} = 10^5 \text{ s } \theta_{obs} = 4^\circ$$

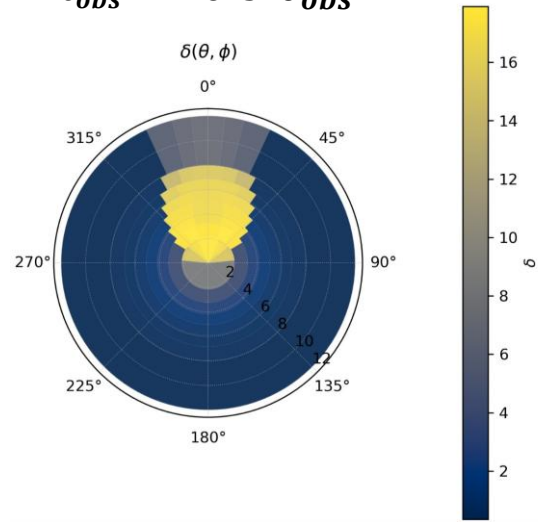

$$t_{obs} = 10^5 \text{ s } \theta_{obs} = 8^\circ$$

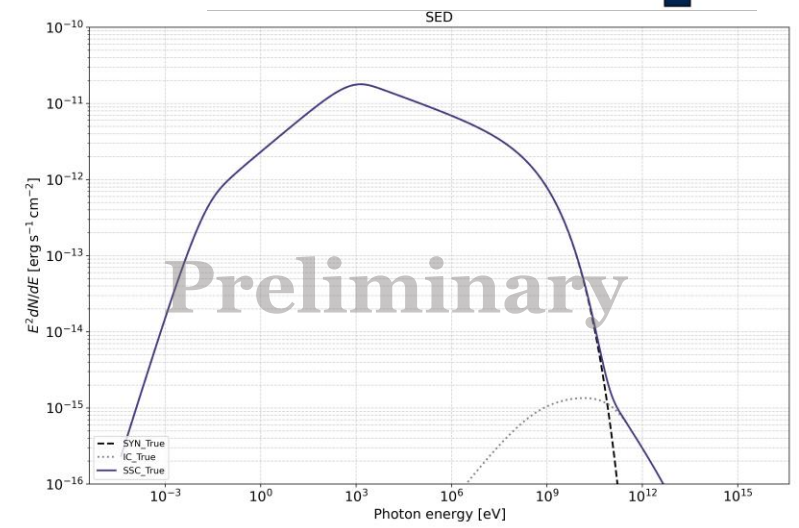
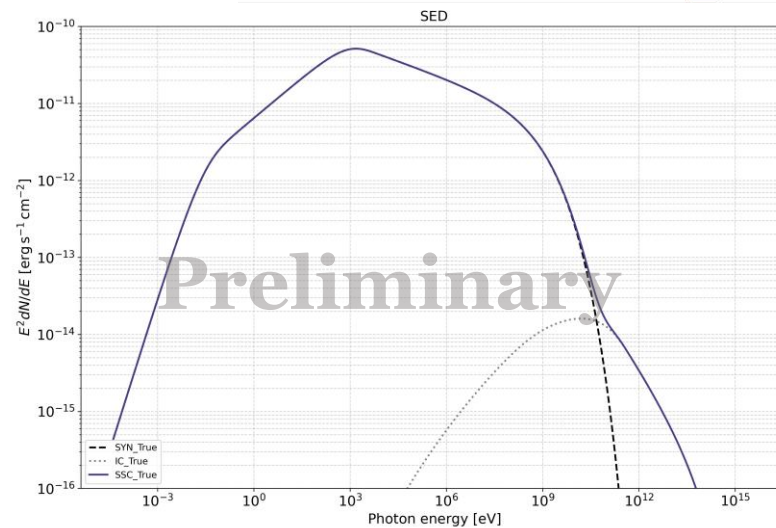
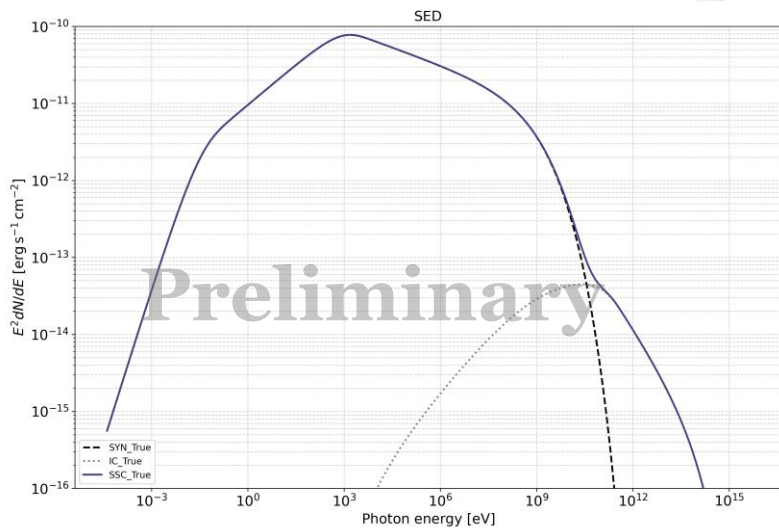
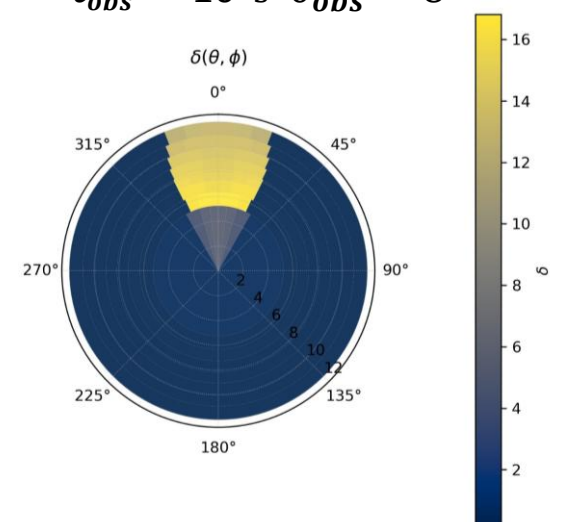

Spectral Energy Density ($t_{\text{obs}} = \text{fixed}$)

$$t_{\text{obs}} = 4 \times 10^5 \text{ s} \quad \theta_{\text{obs}} = 0^\circ$$

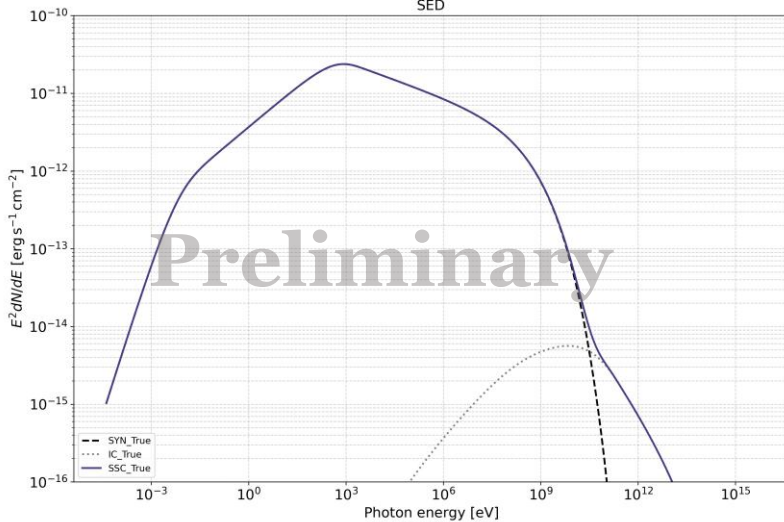
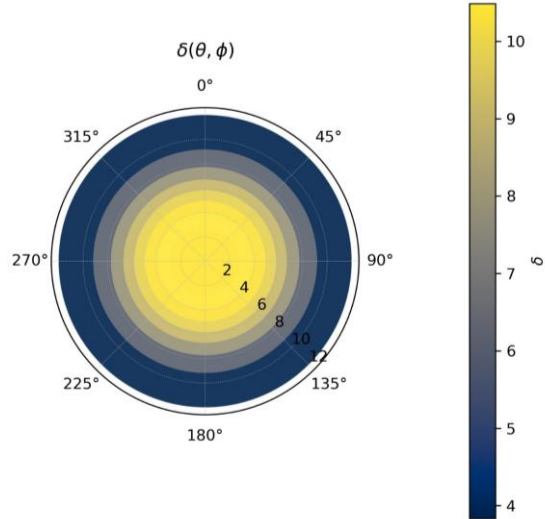

$$t_{\text{obs}} = 4 \times 10^5 \text{ s} \quad \theta_{\text{obs}} = 4^\circ$$

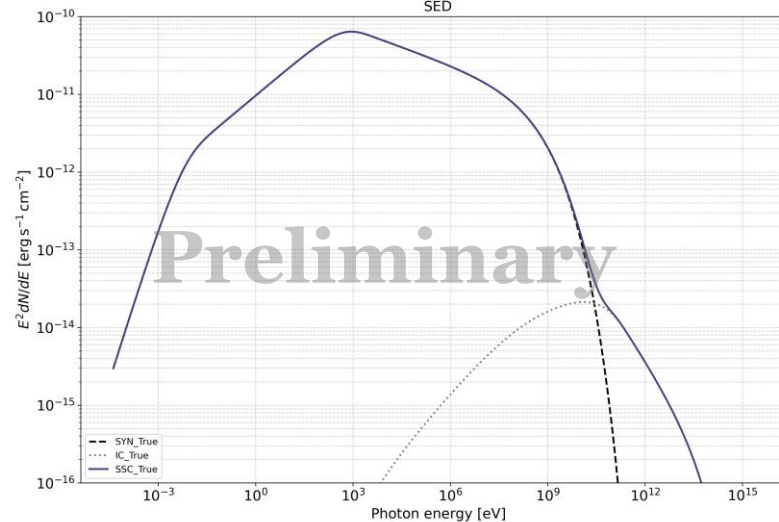
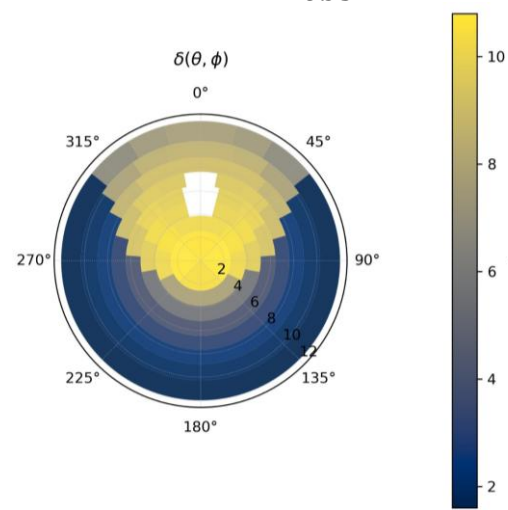

$$t_{\text{obs}} = 4 \times 10^5 \text{ s} \quad \theta_{\text{obs}} = 8^\circ$$

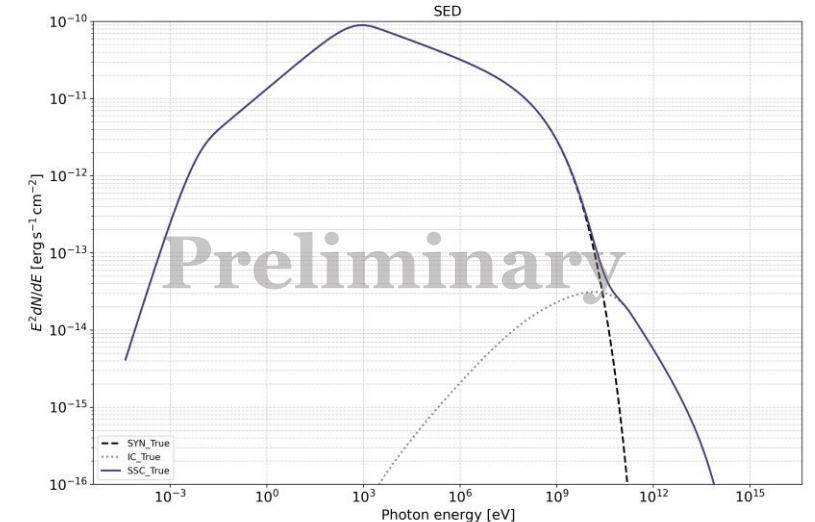
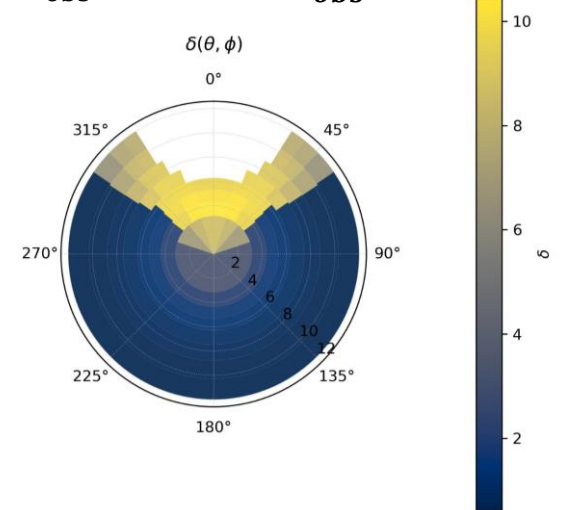

Final Summary and future Goals

Summary

- We ended the first phase of the **SSC code** development: **good off axis behavior**
- **Preliminary flux** results on different observing times: **checking the code**

Future Goals

- Implementetion of **lightcurves** generation: **ongoing**
- Start to test the code in the **full analysis process**:
computation of the expected detection probability for **NSBH multi messenger events**





Thanks for your attention !





Backup slides



Cherenkov Telescopes Array Observatory



Array Coordinates

Latitude: 24° 41' 0.34" South
Longitude: 70° 18' 58.84" West

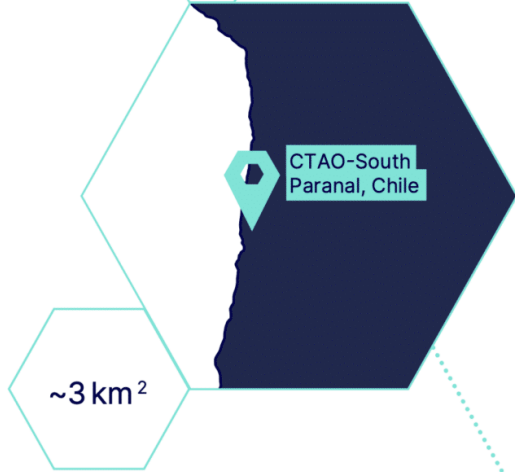

CTAO-South
Paranal, Chile

~3 km²

area covered by the
array of telescopes

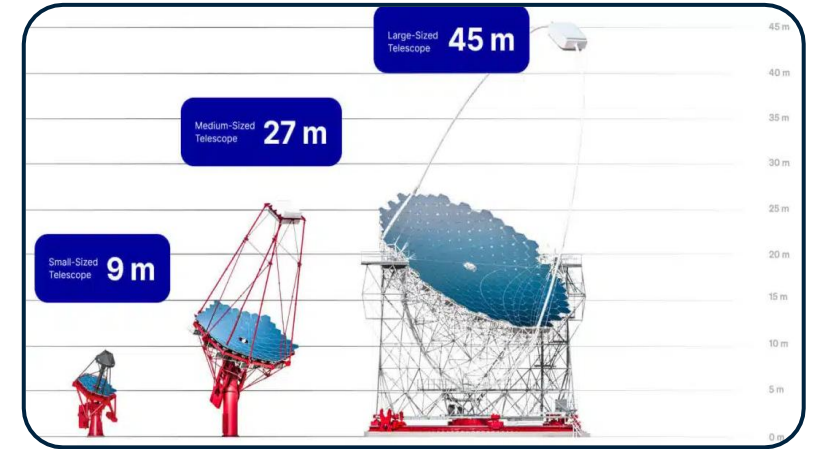

Small-Sized
Telescope

9 m

Medium-Sized
Telescope

27 m

Large-Sized
Telescope

45 m

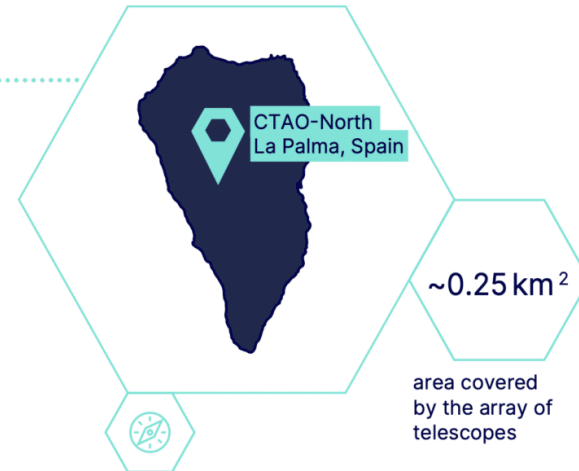

CTAO-North
La Palma, Spain

~0.25 km²

area covered
by the array of
telescopes

Array Coordinates

Latitude: 28° 45' 43.7904" North
Longitude: 17° 53' 31.218" West



Deceleration Radius

Not every R of the *EATS* is valid: R must be $>$ deceleration Radius (R_{dec})

$$R_{dec} = \left(\frac{3E(\theta)}{4\pi n m_p c^2 \Gamma_0^2} \right)^{1/3}$$

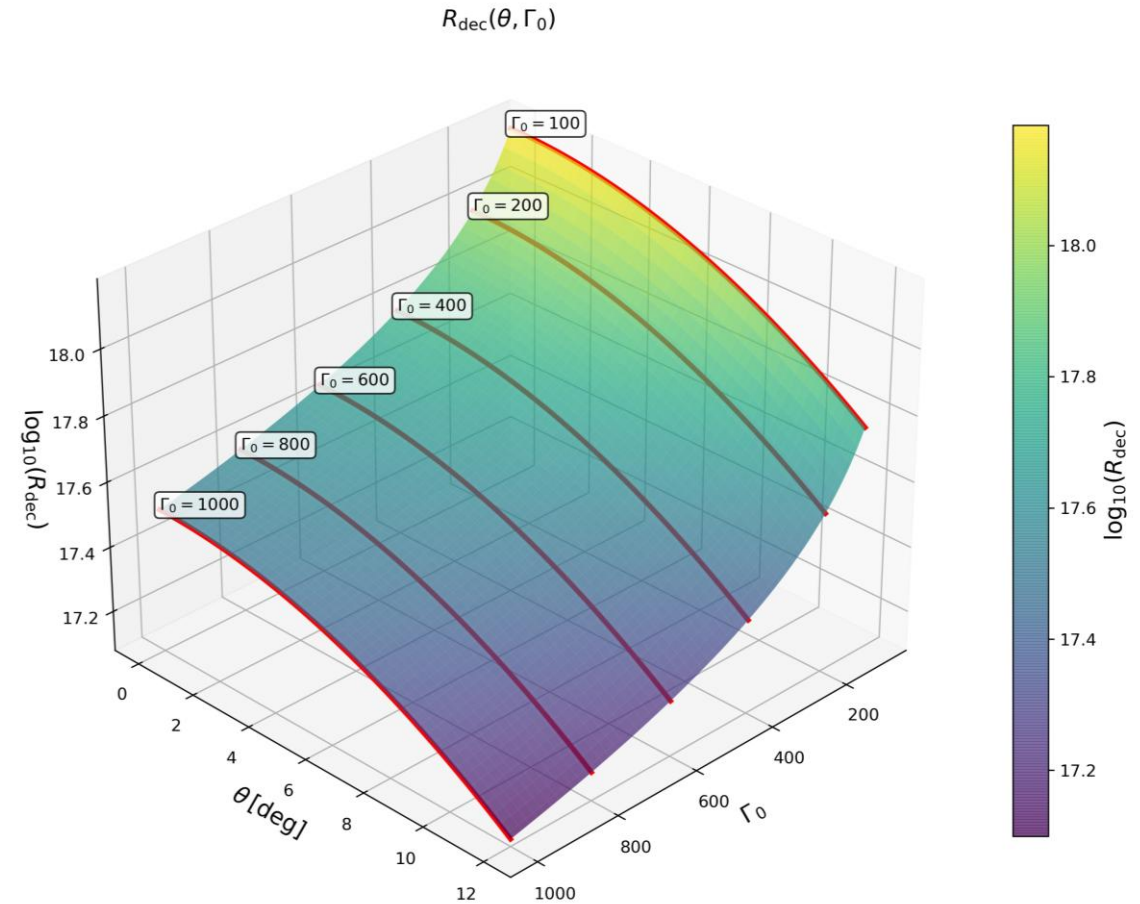
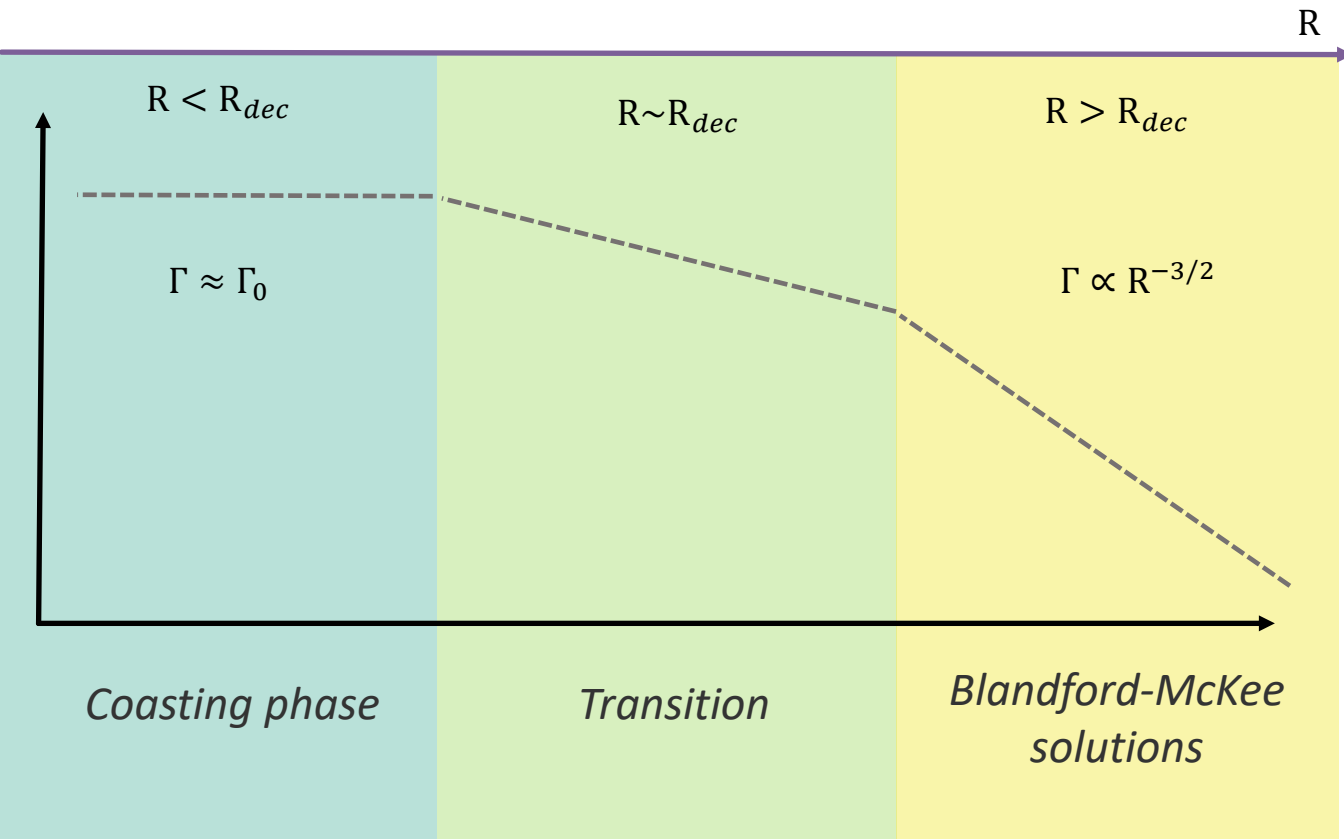

Methods and Analysis

1

Expected **merger rate** throughout the universe

2

Simulation of Gravitational Waves detection

3

Mass **remnant** and kinetic **energy model** for GRB production

4

Very High energy **afterglow evaluation**

5

Expected probability of detection for **NSBH multi messenger** events

1

Expected Merger Rate Estimation

Number of expected NSBH events in the Redshift function.

Local merger rate as $\dot{n}(0) = 45 \text{Gpc}^{-3} \text{yr}^{-1}$

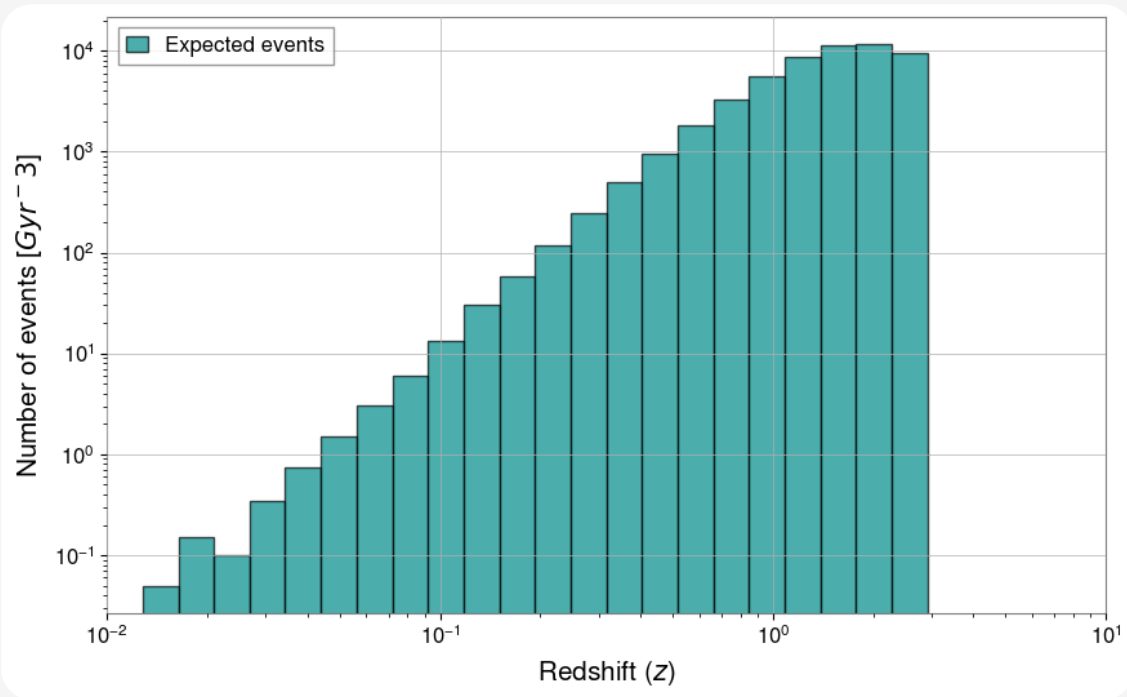

Fig 1. Merger rate of NSBH merger events as a function of redshift (z) vs the number of expected events in z shells.

2

GW Detection Simulation

To simulate the detection we use the **Fisher Matrix** approach using **GWFish** (o GWFast): fast but not precise like the Bayesian approach

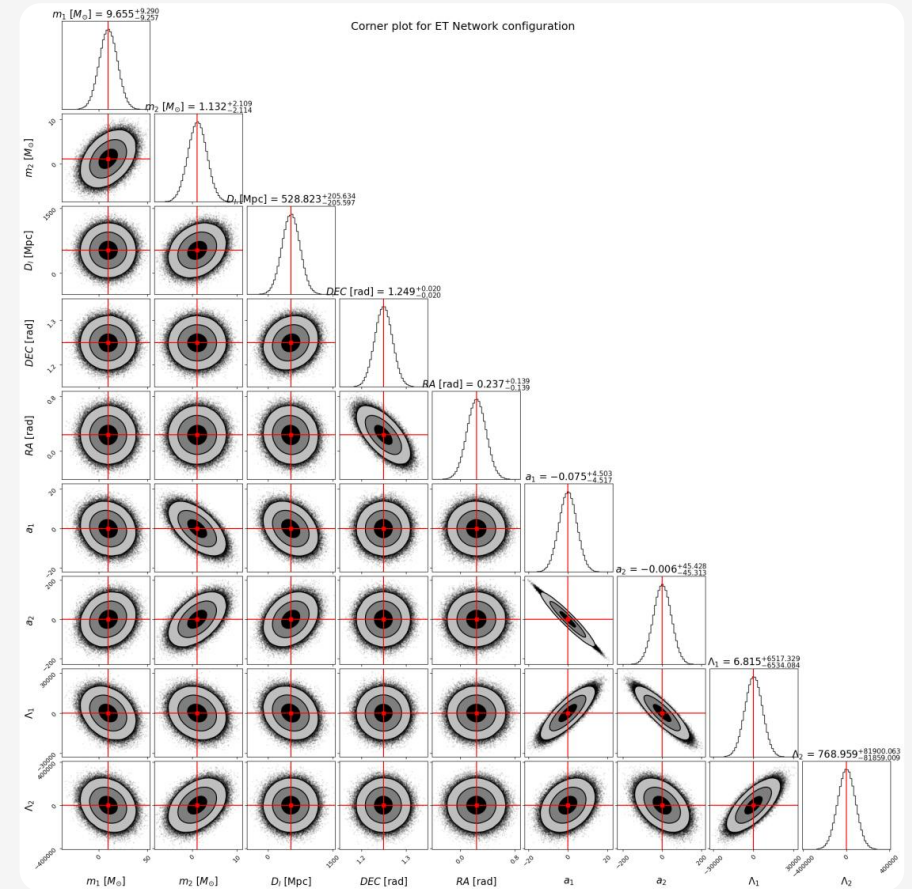

Fig. 2: Parameter estimation with GWFish.

Mass Remnant and Kinetic Energy

Choose the models:

- Amount of mass in the accretion disk (M_{acc})
- Energy of the produced jet (E_k)

$$E_k = \frac{1}{2}(1 - f_\gamma)\eta_{BZ}M_{acc}c^2$$

- $f_\gamma = 10\%$: Emission efficiency
- η_{BZ} : Mass-energy conversion efficiency
- $M_{acc} \geq 0.03M_\odot$: accreted mass

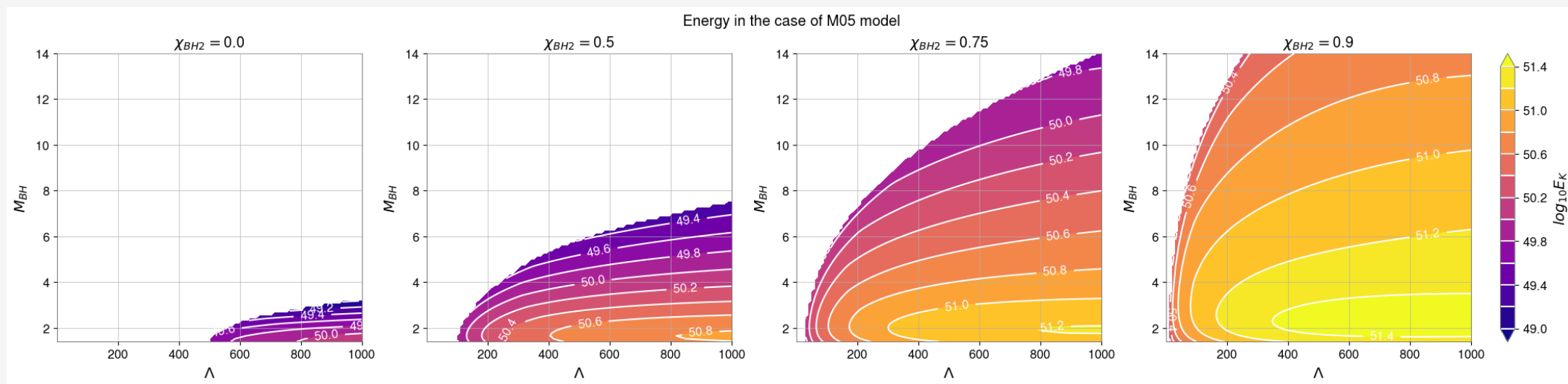
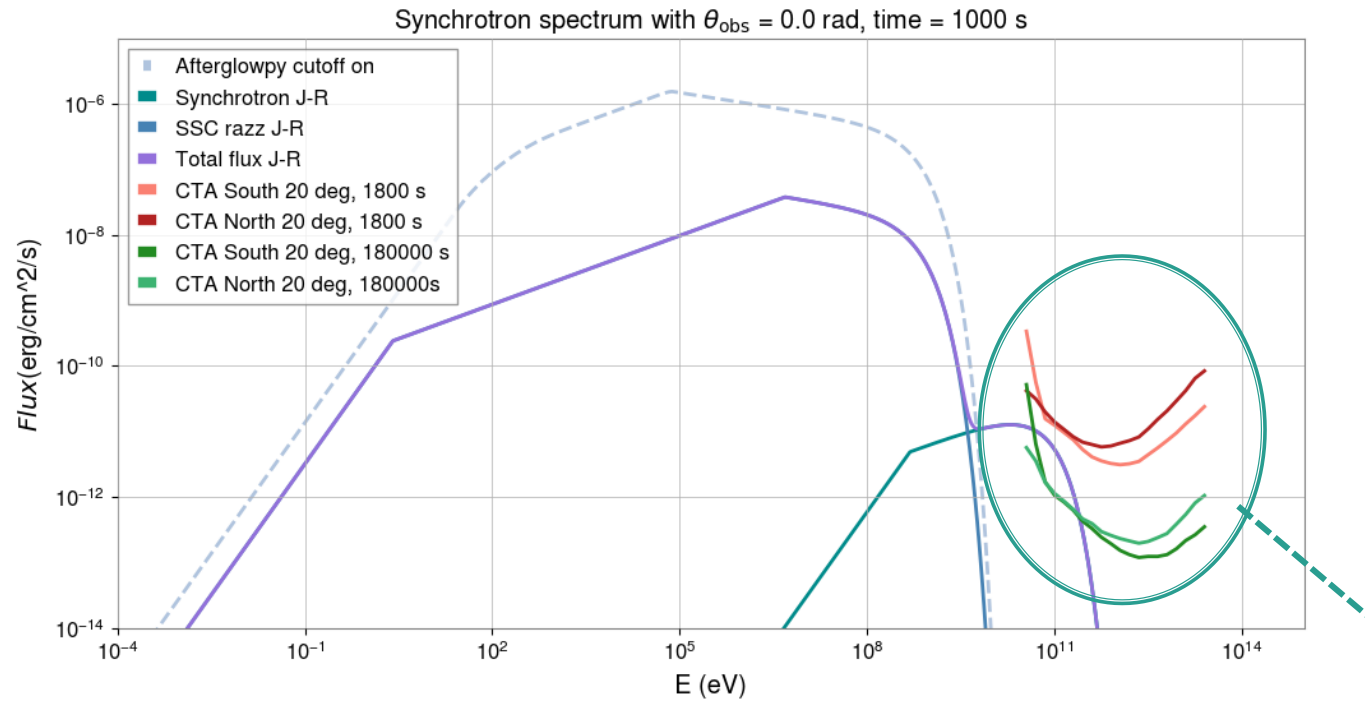
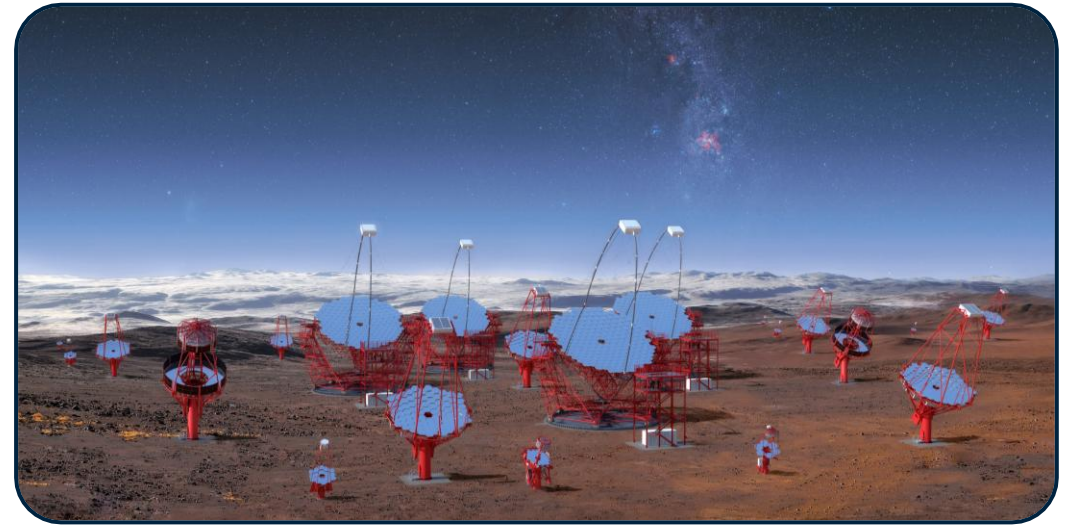

Fig. 3: Contour plots of kinetic Energy (E_k) in function of BH mass, spin a_{BH} and Λ .

CTAO forecasts



CTAO picture of the planned configuration.



Sensitivity curves for CTAO, North and South configuration

Expected Probability of Detection for NSBH Events

Einstein Telescope + CTAO

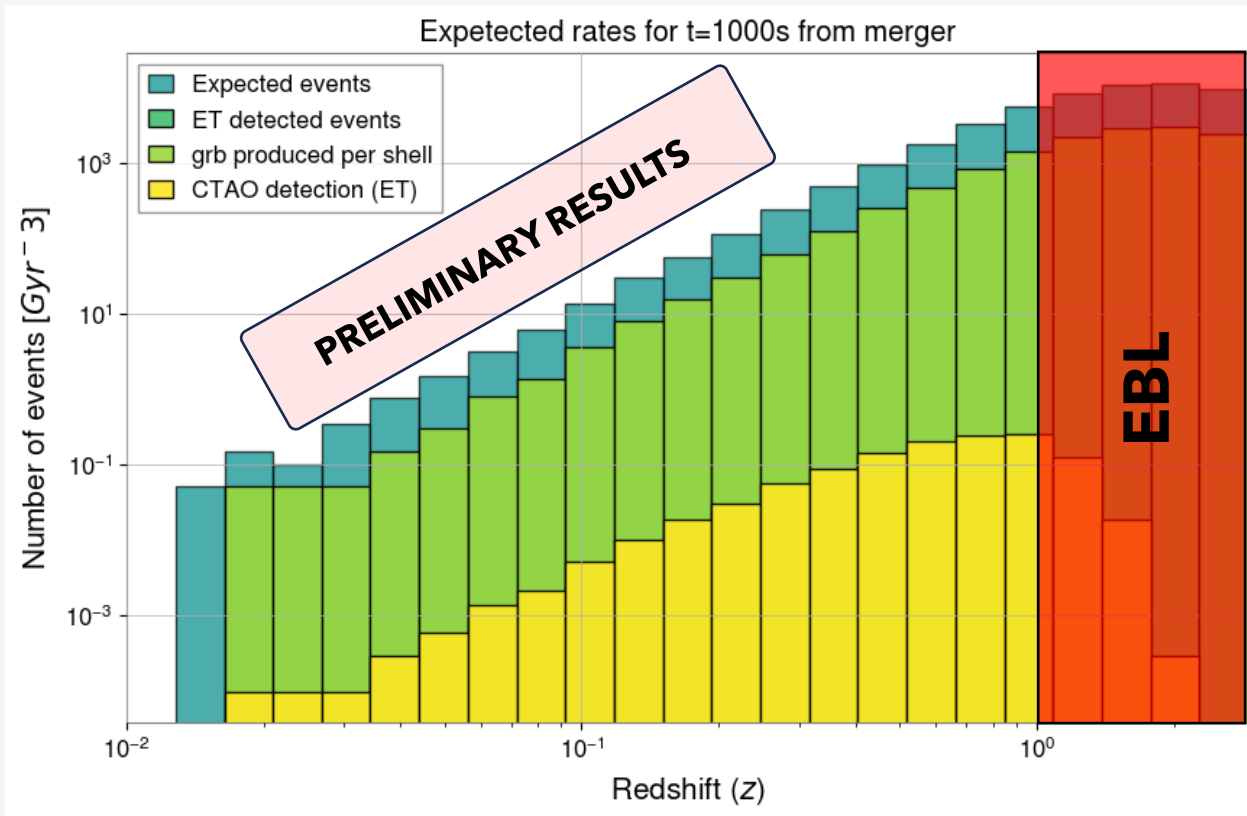

Fig. 5: Histogram of the expected events versus the number of NSBH events detected by ET, the number of GRB produced in every redshift (z) (up to $z=2.7$) and the number of possible detections with CTAO.

The number of possible detections with CTAO is very low, **Why?**

Possible reasons:

- The model used for **the number of expected events is too conservative**: we have more events (especially for low z)
- **Energy conversion** model too conservative
- The **model for the VHE** part of the flux is not the best one



Develop a numerical code for SSC Flux

Synchrotron Self Compton emission

$$\frac{dN_\gamma}{dE_\gamma dt} = \frac{\sqrt{3}}{2\pi} \frac{e^3 B}{m_e \hbar E_\gamma} F\left(\frac{E_\gamma}{E_c}\right)$$

$$F(x) = x \int_x^\infty K_{5/3}(\tau) d\tau$$

$$E_c = \frac{3e\hbar B \gamma^2}{2m_e c}$$

Over directions of magnetic field

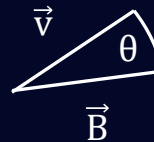

Taking $B_\perp = B \sin\theta$

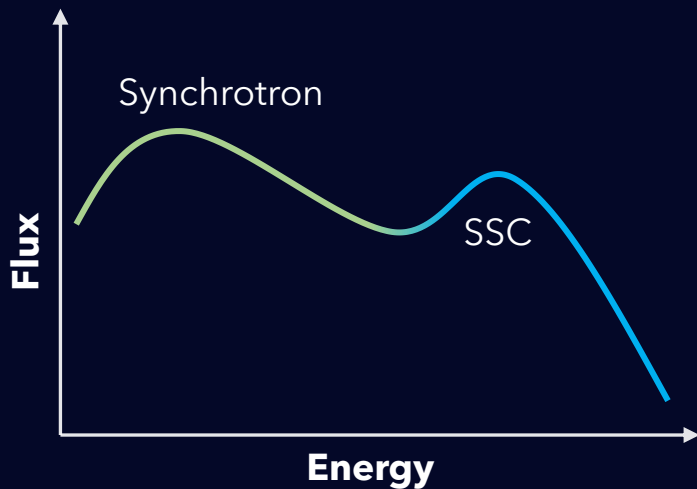

we come to :

$$G(x) = \int_0^\pi F\left(\frac{x}{\sin\theta}\right) \sin^2\theta d\theta \approx \tilde{G}(x)$$

+

$N_e(\gamma)$

Electronic distribution (Broken power law)

$$\frac{dN_\gamma}{dE dt} = \int N_e(\gamma) \frac{dN_\gamma}{dE_\gamma dt} d\gamma$$

CTAO forecasts

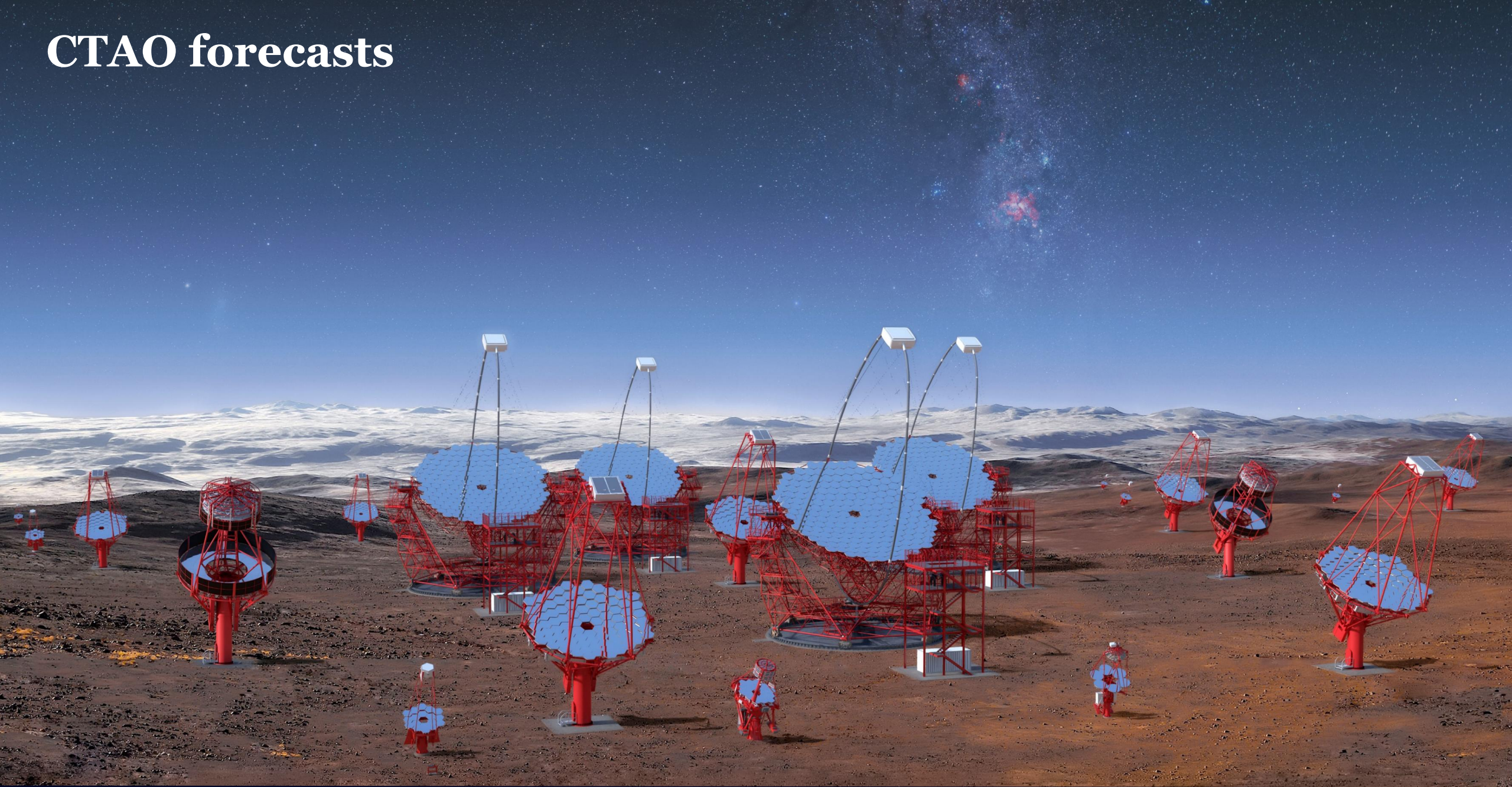

Main goals

Using proper models or tools we can study what happens at very high energies, in that band of the spectrum dominated by Synchrotron Self Compton (SSC).

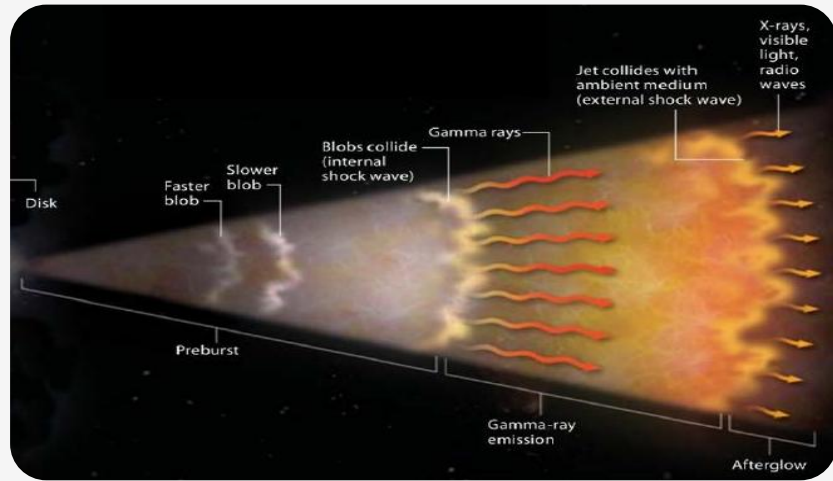

We need more precise models for the Very High Energy spectrum

1) Develop a **model for the SSC** and use it to predict the event rate with **CTAO**

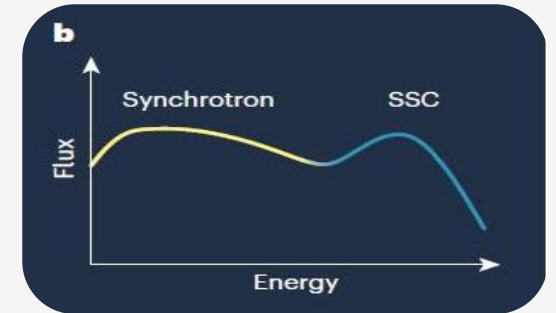

2) Study the **observational strategies** for a faster and more efficient follow-up.

3) **GW and EM joint analysis** to study the **event rate** and the goodness of the **parameter estimation**

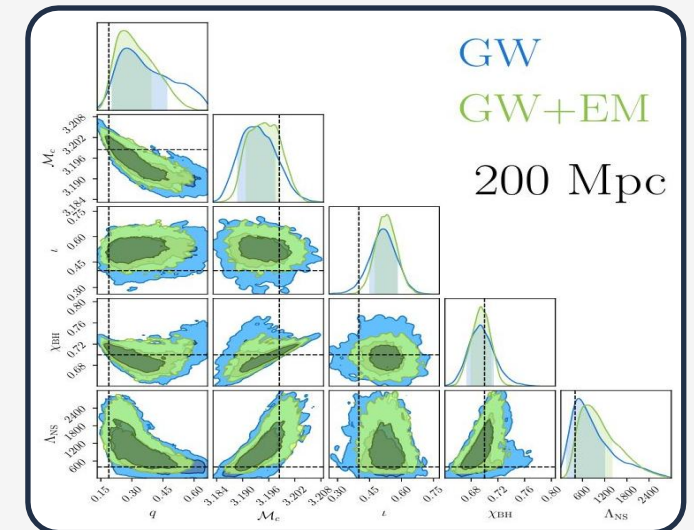

To simulate the detection we use the **Fisher Matrix** approach using **GWFish** (o GWFast): fast but not precise like the Bayesian approach

- Build a dataframe with all the coalescence parameters
- Compute the SNR, parameters values and errors.
- Different network configurations of interferometers.

Einstein Telescope (ET) / ET plus Cosmic Explorer (CE).

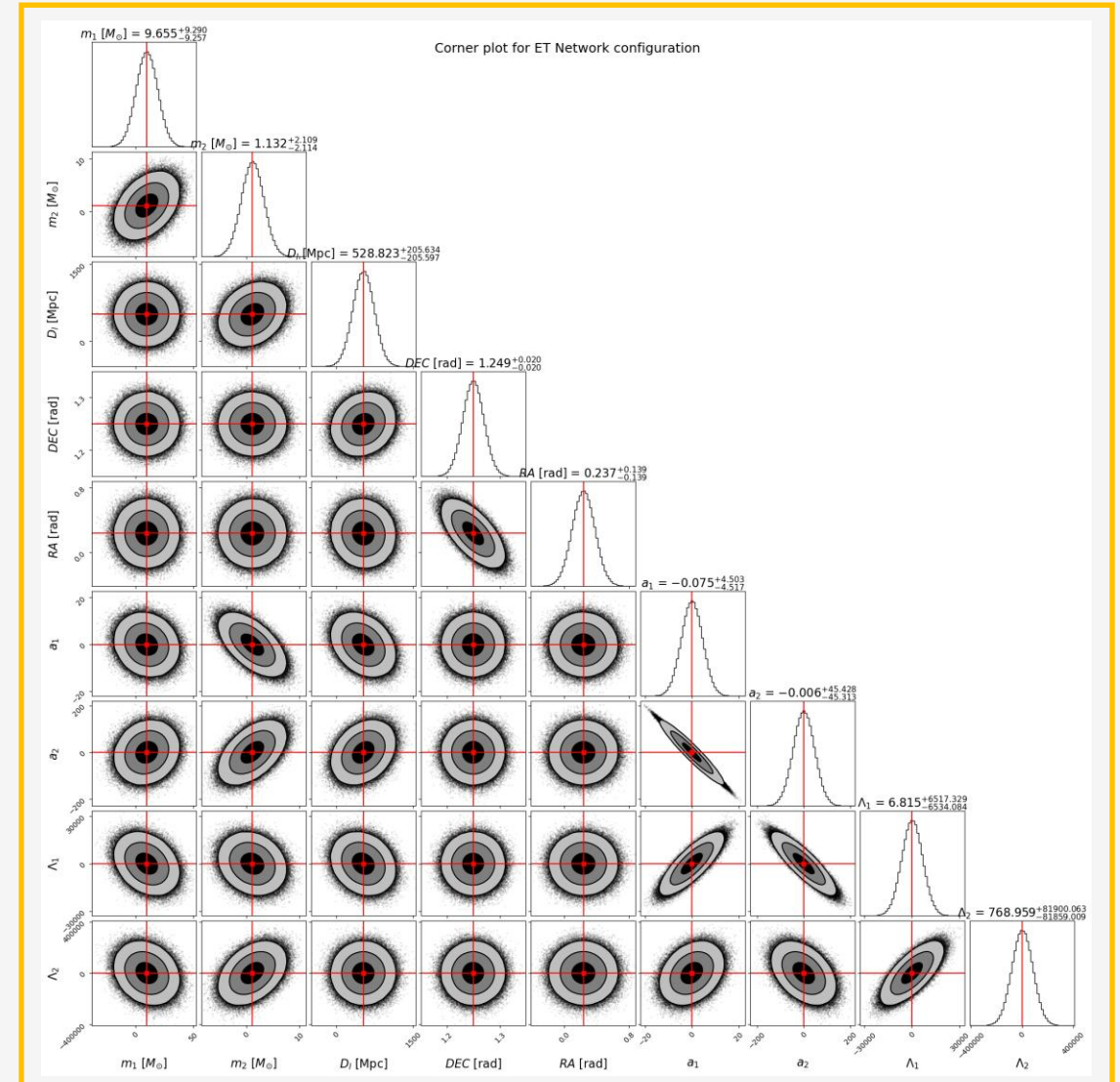

Fig. 3: Parameter estimation with GWFish.

To simulate the detection we use :

- **Fisher Matrix** approach con **GWFish** (o GWFast): less precise but faster

We can build a dataframe with all the coalescence parameters and compute the SNR, parameters values and the corresponding errors for every event. We can study different network configurations of interferometers.

- LIGO-VIRGO-KAGRA (planned for O5 run)
- Einstein Telescope (ET)
- ET coupled with Cosmic Explorer (CE).

Waveform model: IMRPhenomNSBH (LAL suite)

Minimum SNR = 8.0 (Signal to Noise Ratio)

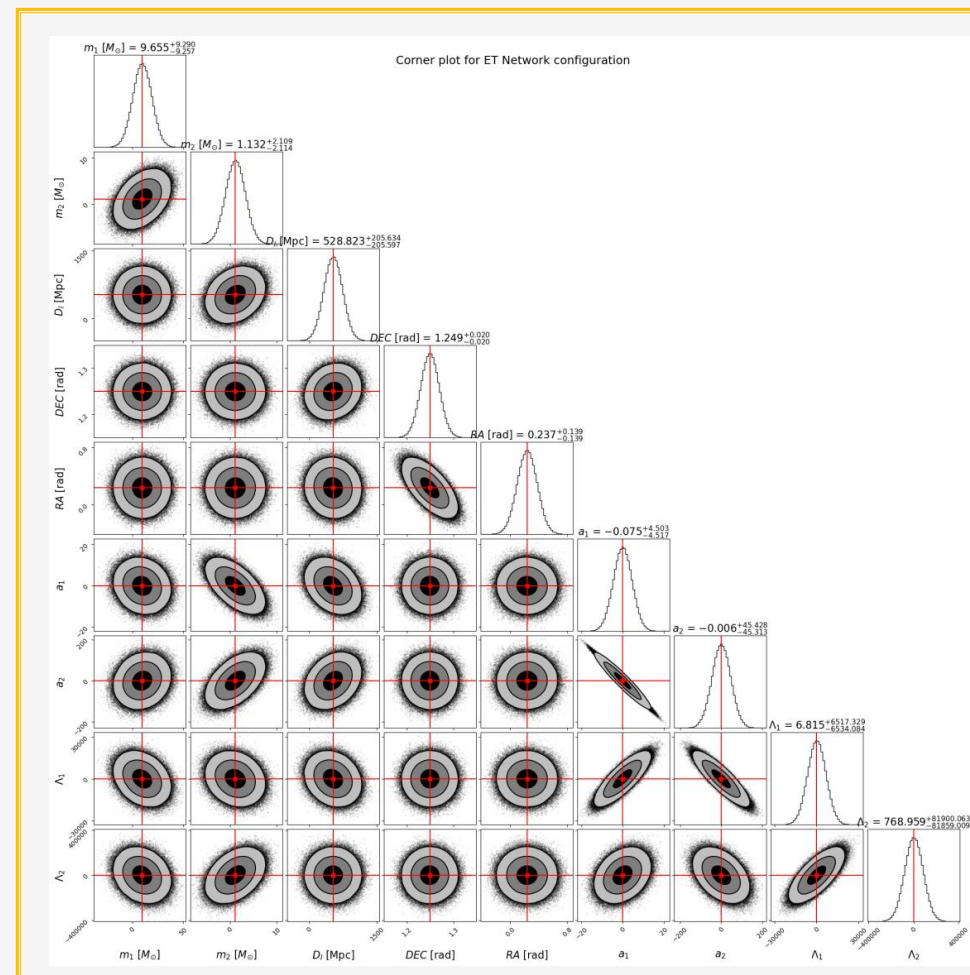

Fig. 3: Parameter estimation with GWFish.

Gravitational Wave detection

To simulate the detection we can use two different approaches:

- **Bayesian** approach with **Bilby** (or pyCBC):
More precise but very slow
- **Fisher Matrix** approach con **GWFish** (or GWFast):
less precise but faster

