

KAGRA CRYOGENICS

- Lesson and Learn

15, MAY, 2026 @KIW14 IN PERUGIA

TAKAYUKI TOMARU ON BEHALF OF KAGRA COLLABORATION

NATIONAL ASTRONOMICAL OBSERVATORY OF JAPAN

KAGRA Cryogenics Issues

- **Thermal Noise Reduction**
 - Mechanical Q of Sapphire Suspension -> M. Otsuka's presentation
 - Mechanical Q of Sapphire Blade Springs
 - Mechanical Q of Sapphire Mirror
 - Gravity Dilution Effect
- **Contamination of Cryogenic Mirror**
 - Vacuum Pressure
 - Stability of Cryocoolers
 - Removal Way of Frosting
- **How to Measure Mirror Temperature**
 - Non-contact Thermometer
- **Long Cooling Time**
 - Heat Switch
 - Good Heat Conductor above 100K

KAGRA Cryogenic System

Type-A Suspension (300K)

Beam Tube (300K)

Main Cryostat
(~10K)

Cryogenic Tube
(Duct Shield, ~100K)

Ultra-Low vibration
Cryocooler (<10K)

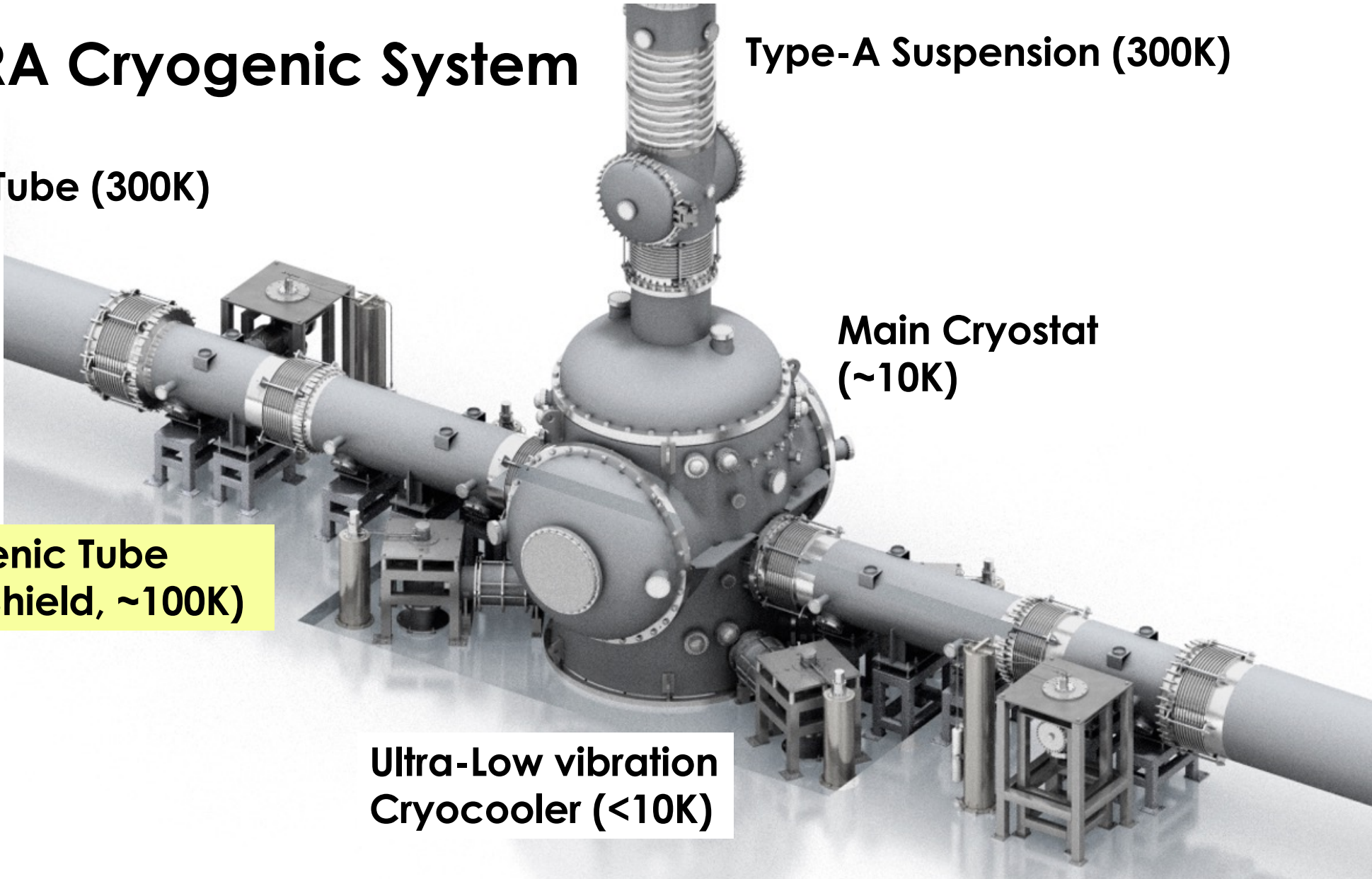

Original Role of Duct Shield

T. Tomaru et al.,
Jpn. J. Appl. Phys. 47 (2008) 1771-1774

Reduction of Thermal Radiation Injection

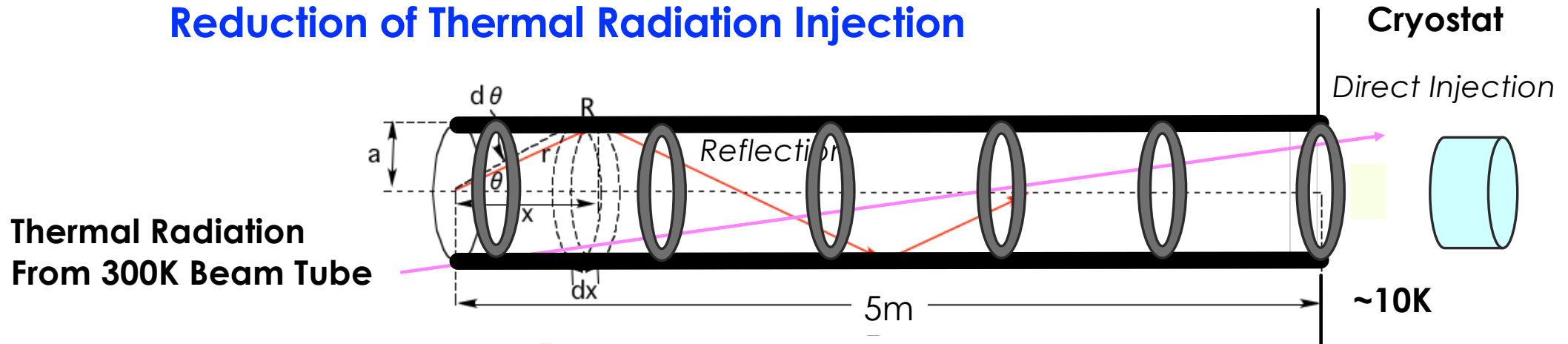

Thermal Radiation
From 300K Beam Tube

$$P_{tot} = P_0 \left[\frac{a^2}{2L^2} + \int_0^L R^{N(x)} \frac{a^2}{(x^2 + a^2)^{3/2}} dx \right]$$

\uparrow
 Direct Injection (P_D)
 $\times \sim 1000$
 \ll
 \uparrow
Reflection (P_R)

**We could cool down
main cryostat only
by four 1W cryocoolers**



**Black
Baffles**

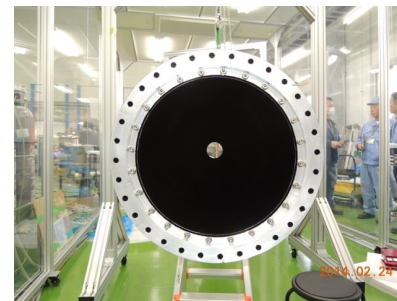

Black Coating

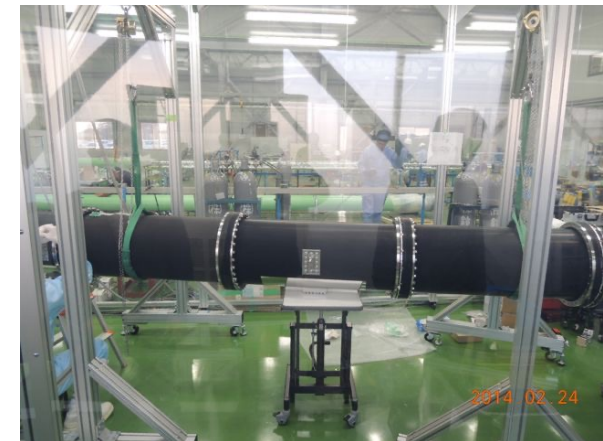

Additional but Critical Role of Duct Shield

Residual Gas Absorber (Cryo-Trap)

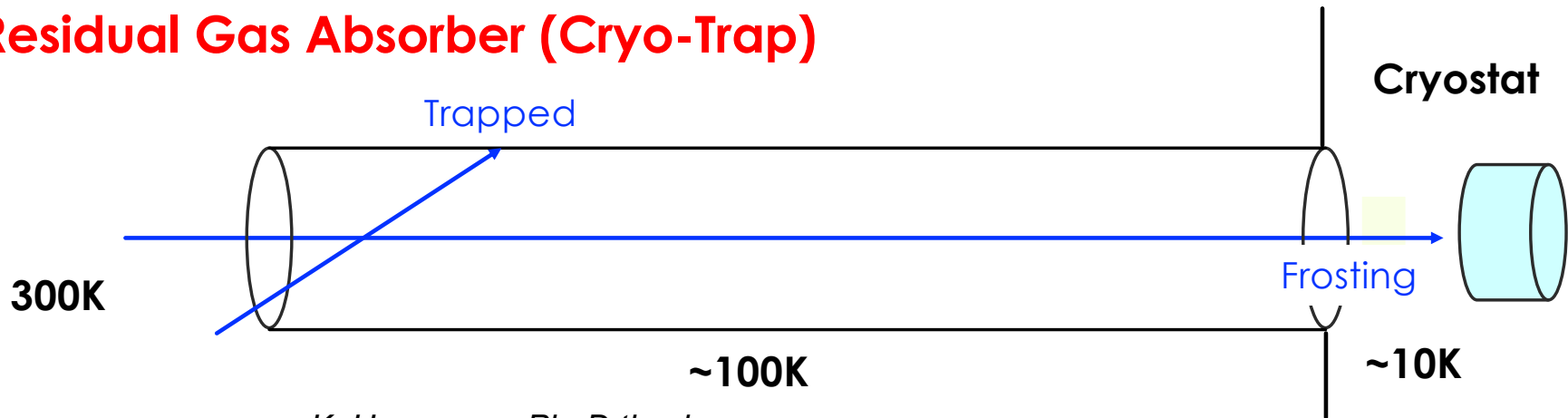

Experimental Setup

*K. Hasegawa, Ph. D thesis,
Univ. Tokyo (2020)*
*K. Hasegawa et al,
Phys. Rev. D 99, 022003 (2019)*

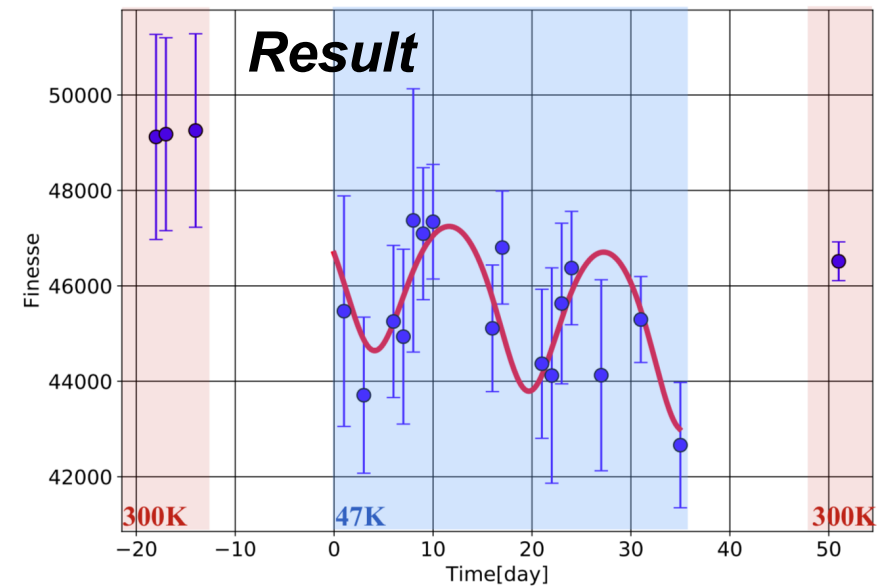
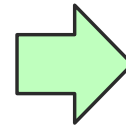
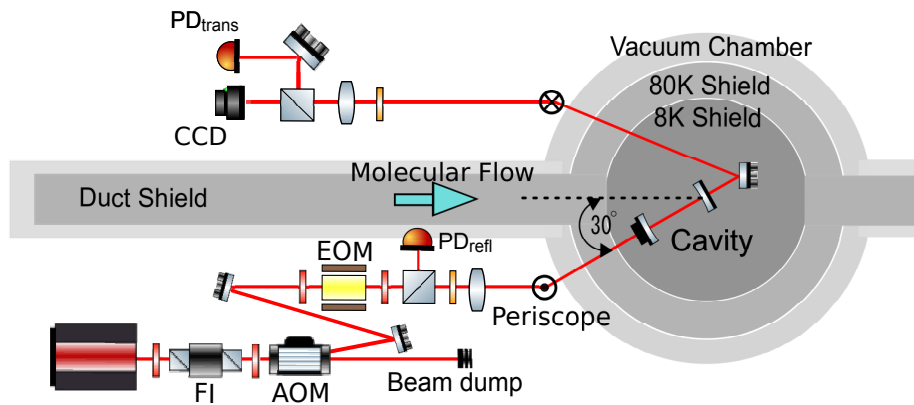

Estimated Speed of Molecular Layer Formation on a Cryogenic Mirror

at Design Pressure (1×10^{-7} Pa)

	Speed	1 month	1 year
H2O	0.56 nm/day	16.8nm	204nm
N2	0.3 nm/day	9nm	110nm
O2	0.23 nm/day	6.9nm	84nm

at Present Pressure (5×10^{-6} Pa)

	Speed	1 month	1 year
H2O	28nm/day	750nm	10um
N2	15nm/day	450nm	5.5um
O2	11.5nm/day	345nm	4.2um

Defrosting heaters are installed on cryogenic mirror suspension in this stage.

Estimated Detection Range of GWs from Binary Neutron Star Coalescence

1pc = 3.3 lyr

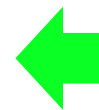
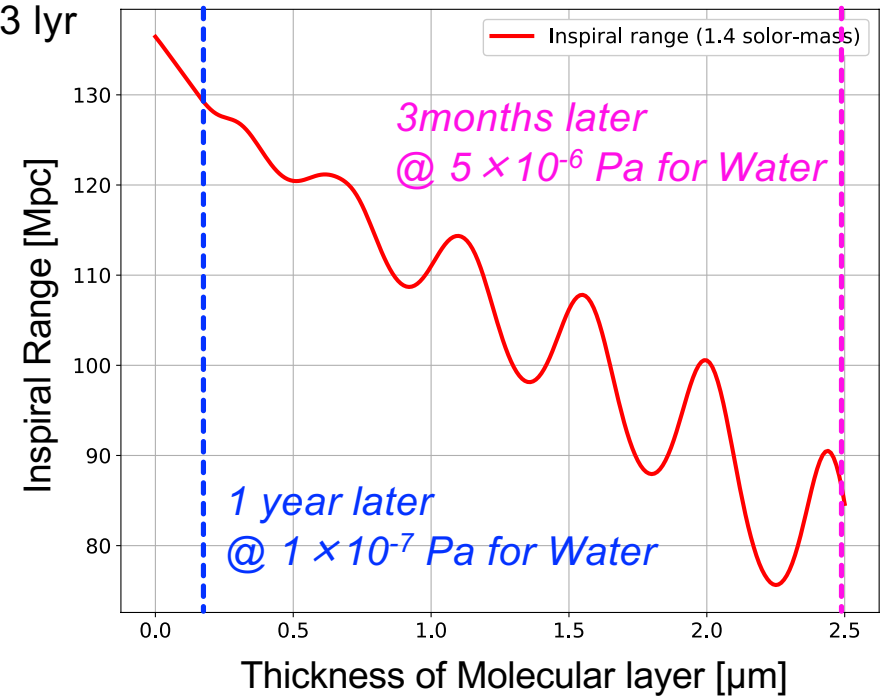

In 5×10^{-6} Pa, the detection range of BNS will reduce from ~ 130 Mpc to ~ 75 Mpc

However, we have still mirror frosting risk

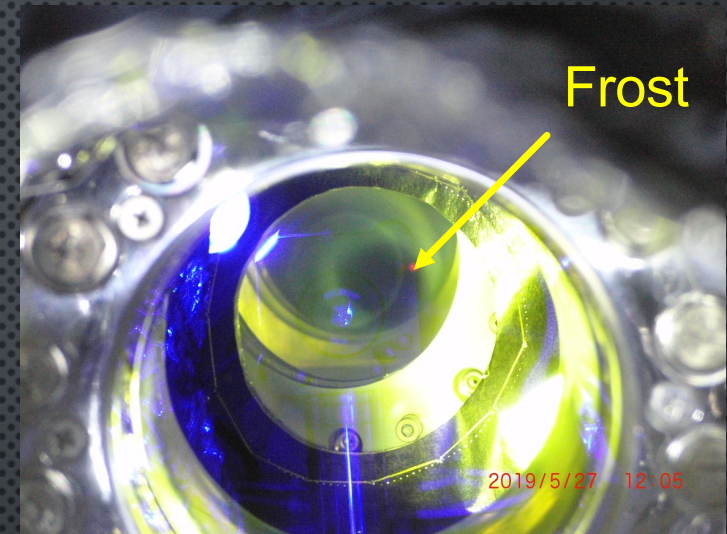
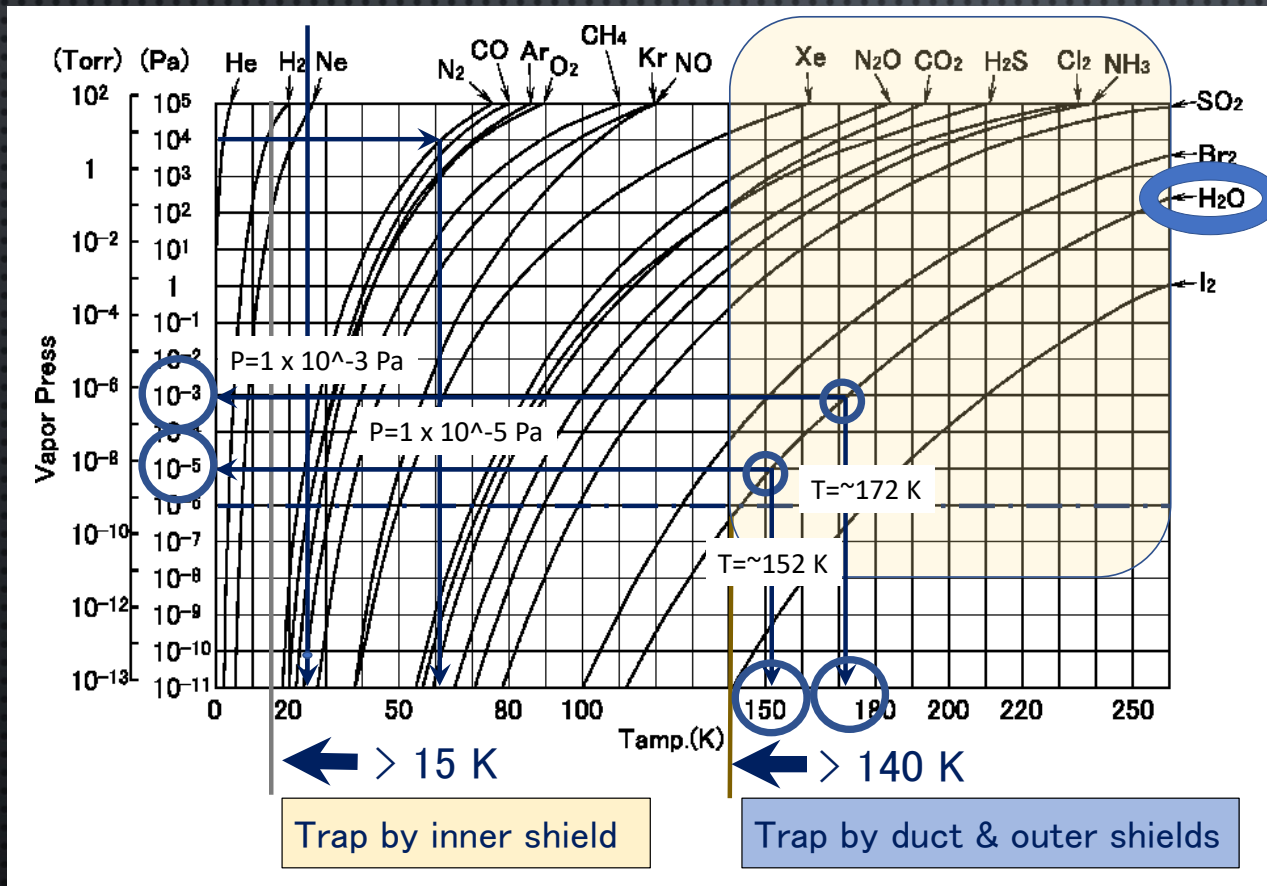

~152K @ 1×10^{-5} Pa
 ~143K @ 1×10^{-6} Pa
 ~147K @ 1×10^{-7} Pa



- Cooling Process
- Vacuum Level
- DS Temperature

Unstable Duct Shield Cryocooler

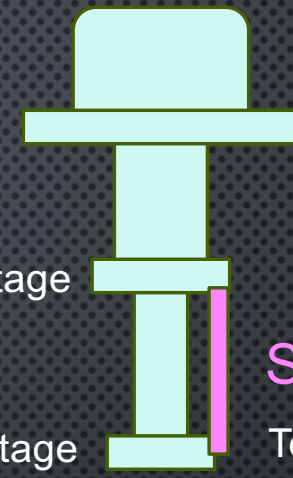
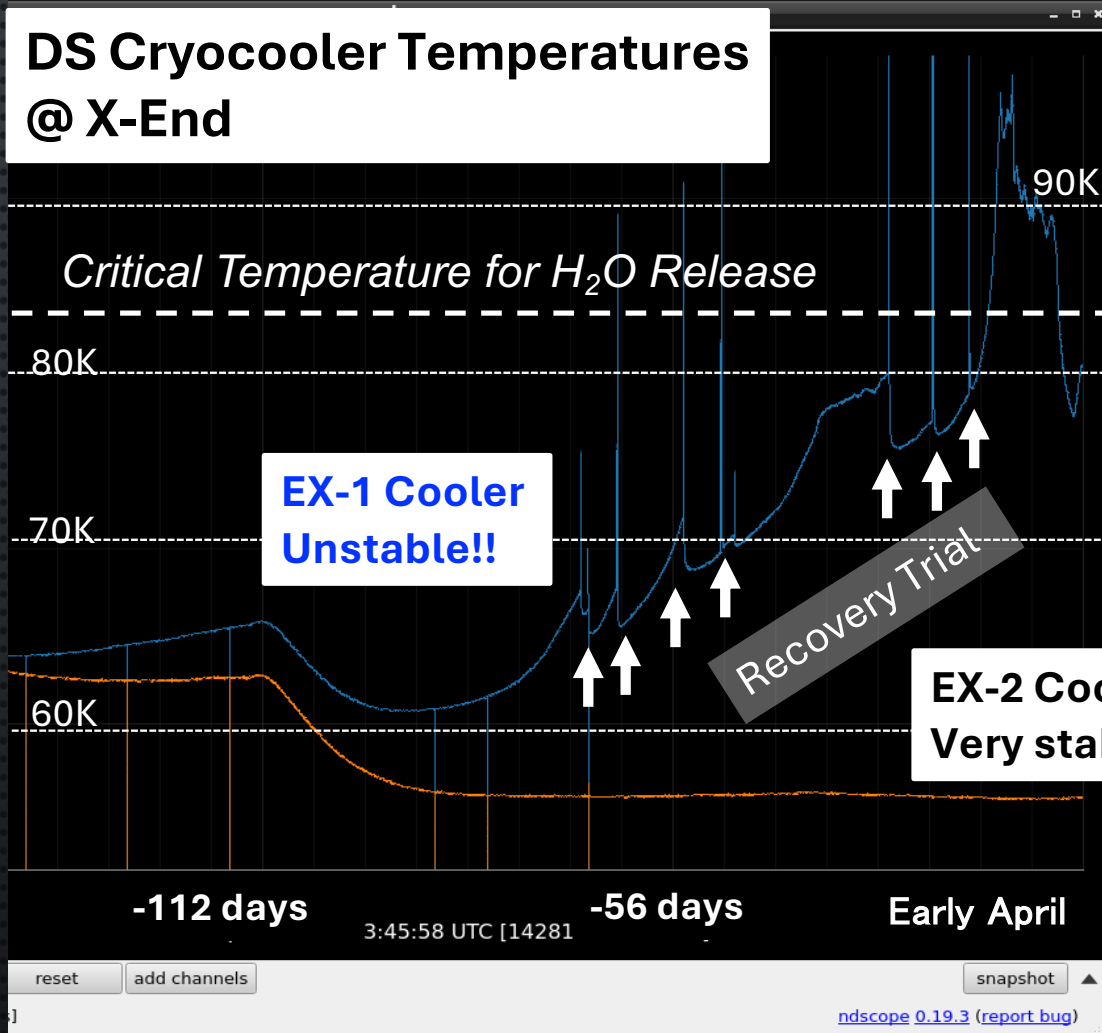

DS Cryocooler Configuration

1st stage
2nd stage

Shorted
To use as a high power 60K cryocooler

- Too high temperature operation?
- Operational He gas contamination?
- Compressor trouble?
- Other reason?

Data: N. Kimura, KAGRA PAB meeting presentation

Dual Cryocooler Upgrade Plan for DS

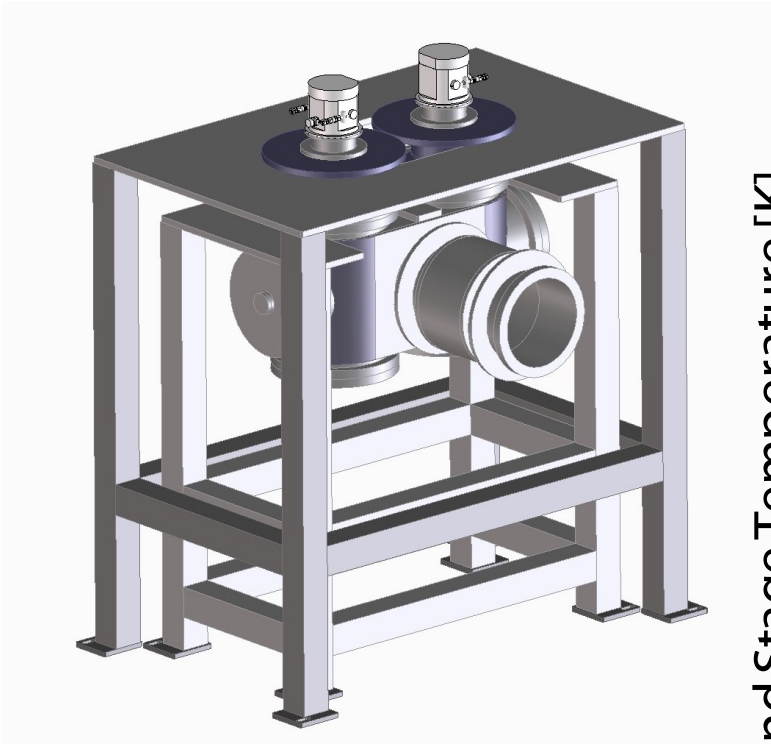

Dual Cryocooler configuration

Single Cryocooler configuration

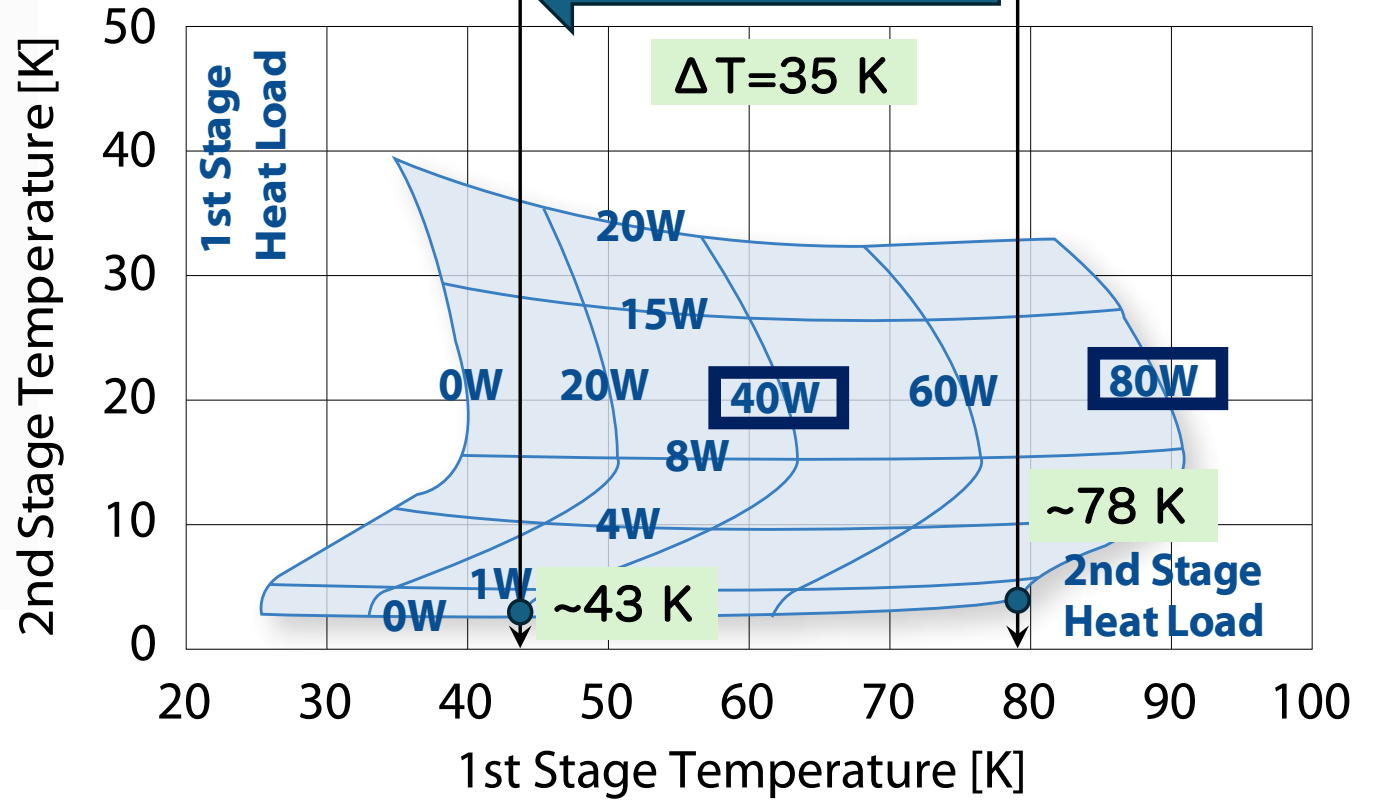

Defrosting

T. Ushiba, KAGRA PAB meeting presentation

We installed a heater before O4

Estimated temperatures of TM and IM in 10W heat at IM

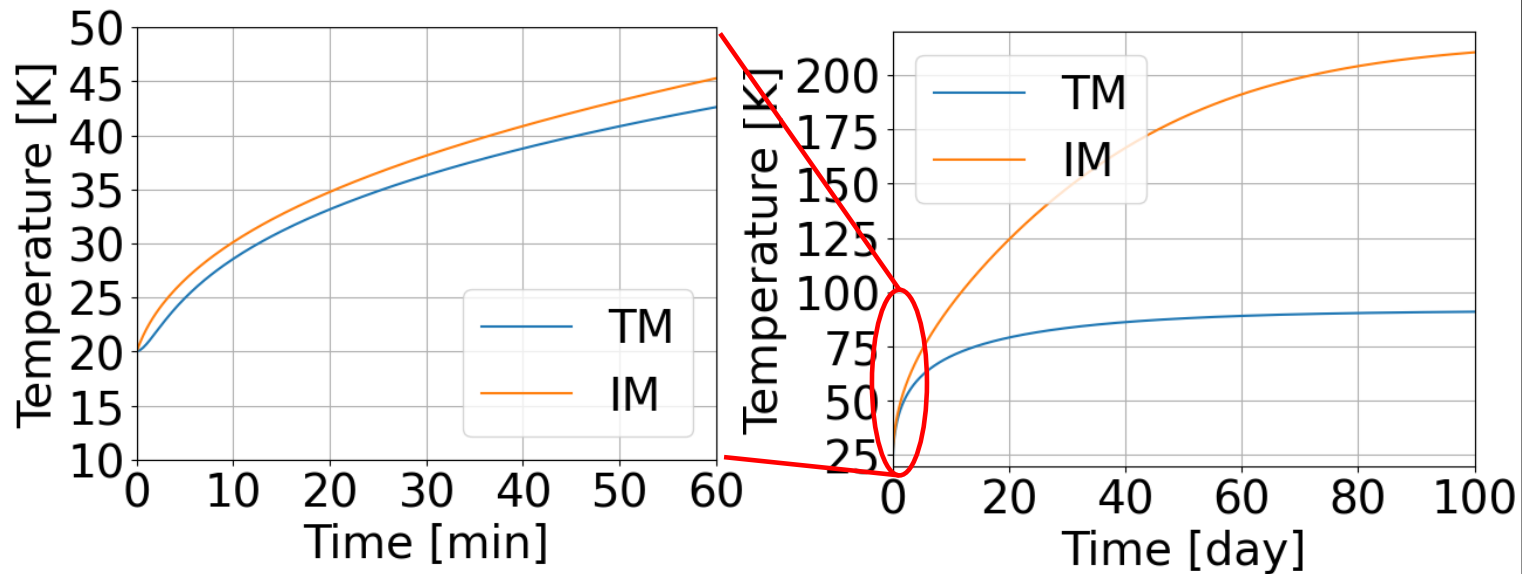

The IM heater is not so effective and can not defrost H₂O.

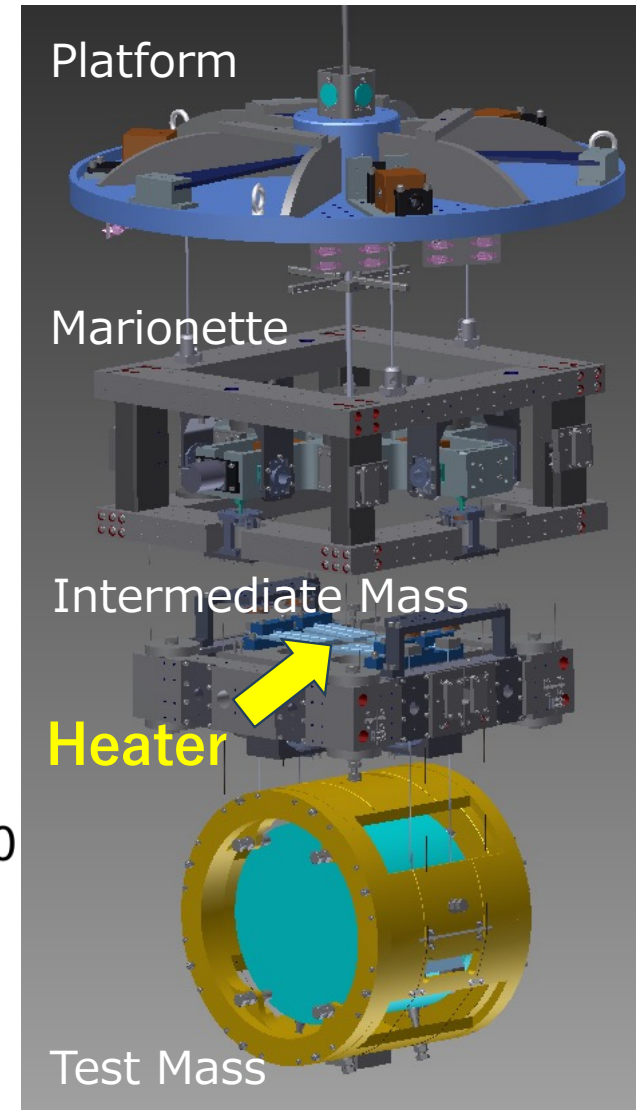

Defrosting Plan by Laser Irradiation on a Mirror

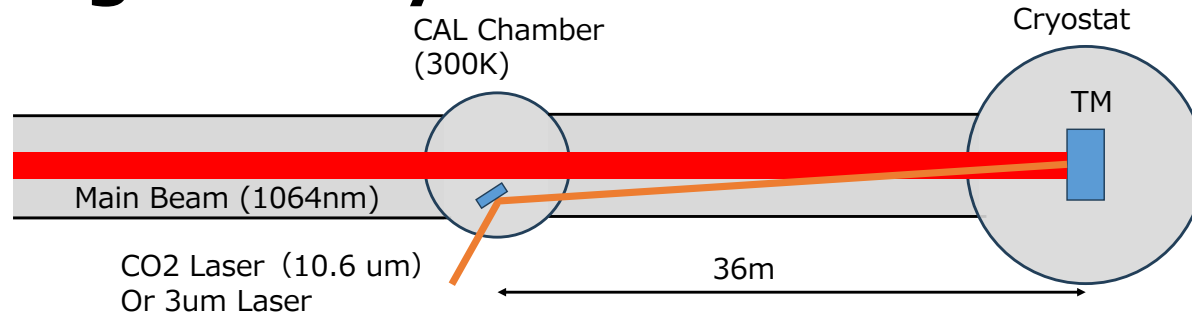

T. Ushiba, KAGRA PAB meeting presentation

Required Time of H₂O Defrosting

Assuming 80% CO2 laser power is absorbed at TM

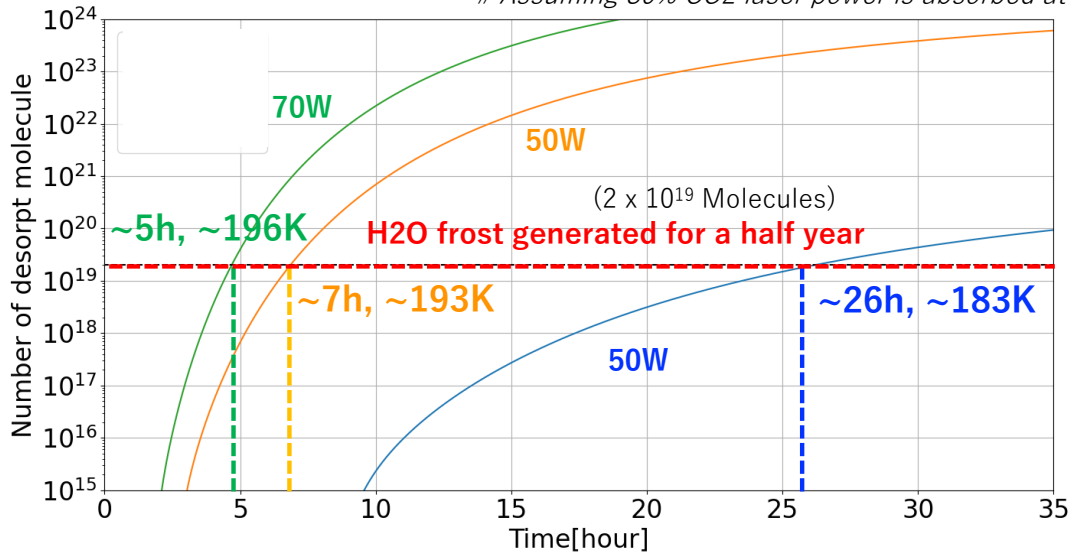

Re-Cooling Time

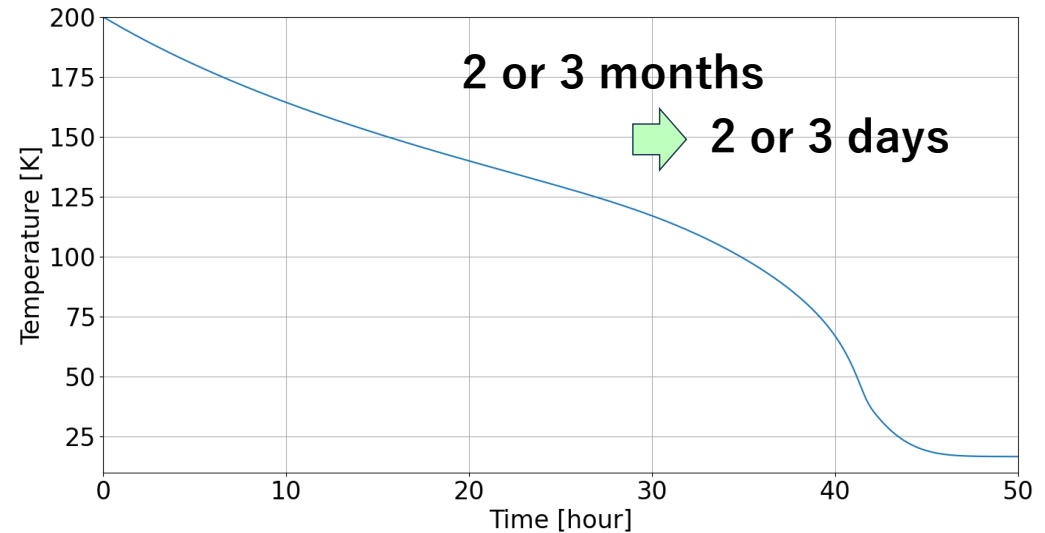

2 or 3 days recovery is possible

Summary

- The Duct Shield is important not only for thermal radiation reduction but also residual gas absorber.
- Mirror frosting is serious issue in KAGRA
 - It is difficult to avoid frosting
 - 1×10^{-7} Pa is required
- Stabel 60K cryocooler is necessary
 - He working gas cleaning
 - Double cryocooler upgrade
- A heater at the IM was not effective
- Defrosting techniques are necessary
 - Laser heating on TM is effective